

## April 2021 Update Pack

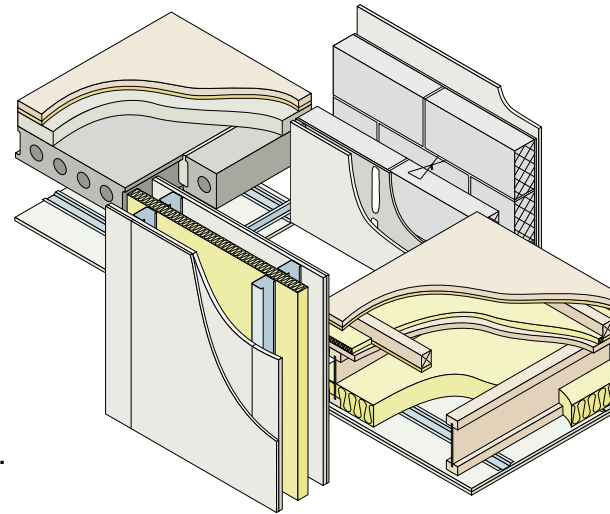

Dear Colleague,

Thank you for downloading this April update – the first of 2021.

In this update, you'll see that Thermal Economics' new fire-retardant IsoRubber FR is approved as an alternative bonded resilient floor covering for use on their E-FC-9 and E-FC-10 floors, and can be laid in place of the existing IsoRubber Top.

In Appendix A2, the Smartroof room-in-roof wall panels have a revised lining specification; and the Space4 room-in-roof roof panels have the option to position the OSB layer uppermost on the roof cassettes.

**Please update your October 2020, 4th Edition Handbook as follows:**

1. Remove and replace **all pages** of E-FC-9.
2. Remove and replace **all pages** of E-FC-10.
3. Remove and replace **pages 1/2 and 3/4** of Appendix A1.
4. Remove and replace **pages 3/4, 7/8 and 13/14** of Appendix A2.
5. Remove and replace **all pages** of Appendix B.

Yours sincerely

A handwritten signature in black ink, reading "John Thompson". The signature is written in a cursive style and is positioned above a horizontal line.

**John Thompson**

Chief Executive,  
Robust Details Limited



# Changes to the fourth edition following April 2021 update

---

Section Page Amendment

## Separating Floor – Concrete

### E-FC-9

---

All 1-6 IsoRubber FR added as alternative bonded resilient floor covering.

### E-FC-10

---

All 1-6 IsoRubber FR added as alternative bonded resilient floor covering.

## Appendix A1

Contents 1 “*and finishes*” added to Internal render listing.

Internal render 4 “*and finishes*” added to Internal render section.

## Appendix A2

Smartroof room-in-roof 3 Item 7 amended to 2 layers gypsum board nominal 19.6 kg/m<sup>2</sup>.

Space 4 room-in-roof 8 New diagram 3 b) added to give the option of the OSB being positioned uppermost.

Private stairs 13 Insulation specification added to timber frame wall leafs.

## Appendix B

Rigid closer 2 Definition added for a rigid closer.

- 3mm Thermal Economics IsoRubber Top or IsoRubber FR ■
- Precast concrete plank ■
- Screed ■

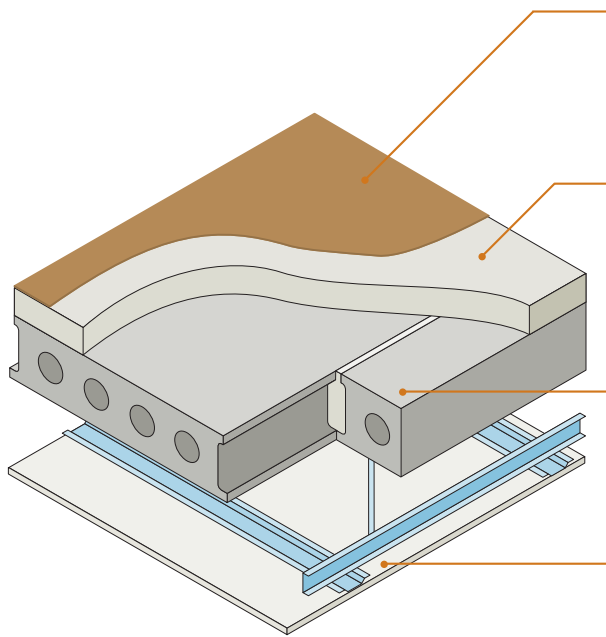

<b>Floor covering</b>	3mm Thermal Economics IsoRubber Top or IsoRubber FR (bonded with IsoBond adhesive)
<b>Screed</b>	65mm (min) sand cement screed, or 40mm proprietary screed, 80 kg/m <sup>2</sup> (min) mass per unit area
<b>Structural floor</b>	Precast concrete plank of 150mm (min) thickness and 300 kg/m <sup>2</sup> (min) mass per unit area
<b>Ceiling</b>	See section 3 for suitable ceiling treatment which is dependent on floor plank depth

## DO

- Butt planks tightly together
- Grout all joints between planks
- Fill all voids between walls and floor
- Ensure IsoRubber Top or IsoRubber FR fully covers floor area
- Make sure ceiling treatment is installed in accordance with the manufacturer's instructions (where applicable)
- Ensure IsoRubber Top or IsoRubber FR is bonded to screed with IsoBond adhesive

## 1. External (flanking) wall junction

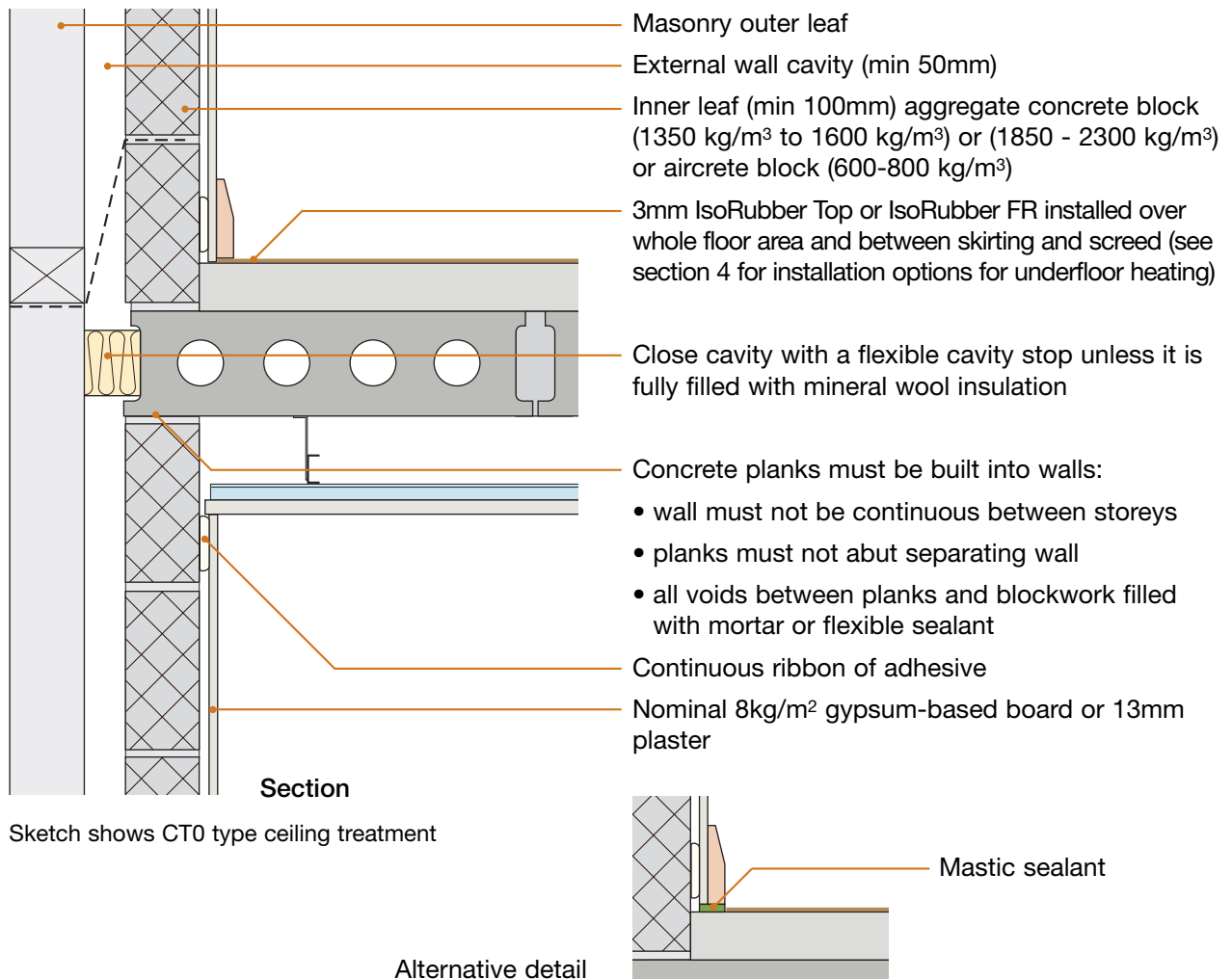

## 2. Separating wall junction

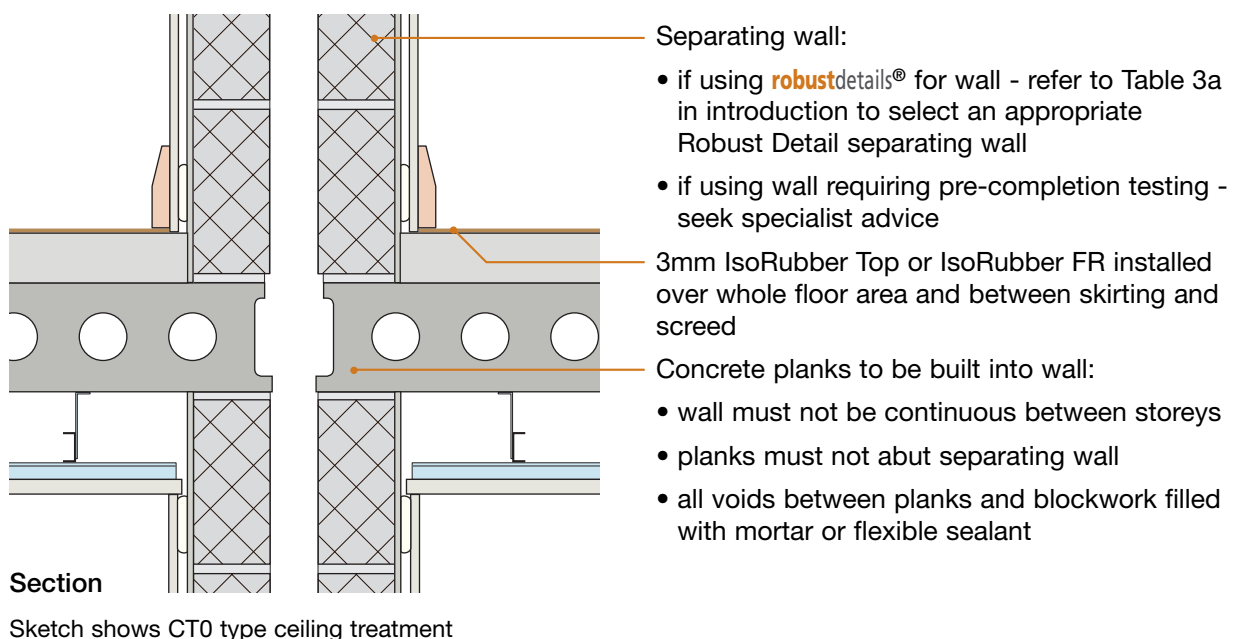

## 3. Ceiling treatments for E-FC-9

All ceiling treatments must be installed in accordance with the manufacturer’s instructions. All ceiling joints should be sealed with tape or caulked with sealant.

Note: the sound insulation performance of all ceiling treatments is increased if:

- 25mm (min.) mineral fibre quilt is placed in the ceiling void, and/or
- if resilient hangers are used.

### Downlighters and recessed lighting

Provided there is a minimum ceiling void, as stated below for CT0 and CT1, downlighters or recessed lighting may be installed in the ceiling:

- in accordance with the manufacturer’s instructions
- at no more than one light per 2m<sup>2</sup> of ceiling area in each room or see Appendix F
- at centres not less than 0.75m
- into openings not exceeding 100mm diameter or 100x100mm

Particular attention should also be paid to Building Regulations Part B - Fire Safety

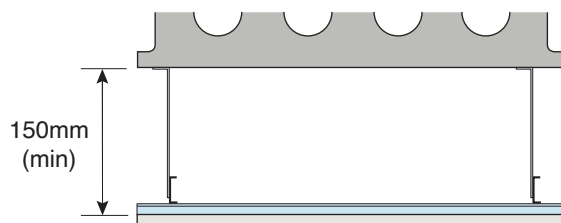

### CT0 – Metal ceiling system - 150mm void To be used for 150mm (min) depth concrete planks

- any metal ceiling system providing 150mm (min) ceiling void
- one layer of nominal 8 kg/m<sup>2</sup> gypsum-based board

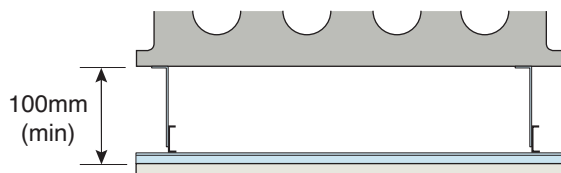

### CT1 – Metal ceiling system – 100mm void Only to be used for 200mm (min) depth concrete planks

- any metal ceiling system providing 100mm (min) ceiling void
- one layer of nominal 8 kg/m<sup>2</sup> gypsum-based board

## 4. Underfloor heating systems within screeds

Underfloor heating systems may be installed within the screed.

Appropriate screed depth cover to the heating system must be designed for – contact underfloor heating manufacturer for guidance.

**Note:** If required it is permissible to have an insulation layer between screed and plank (as shown in Option B).

### OPTION A

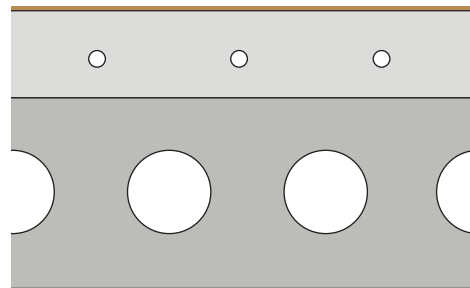

### OPTION B

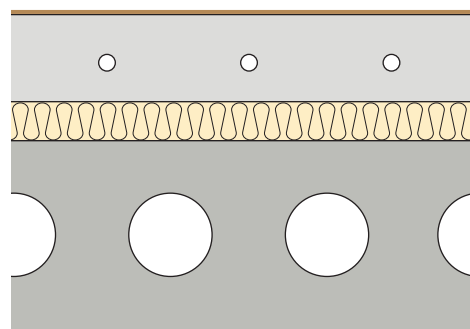

## 5. Services – Service pipes through separating floor

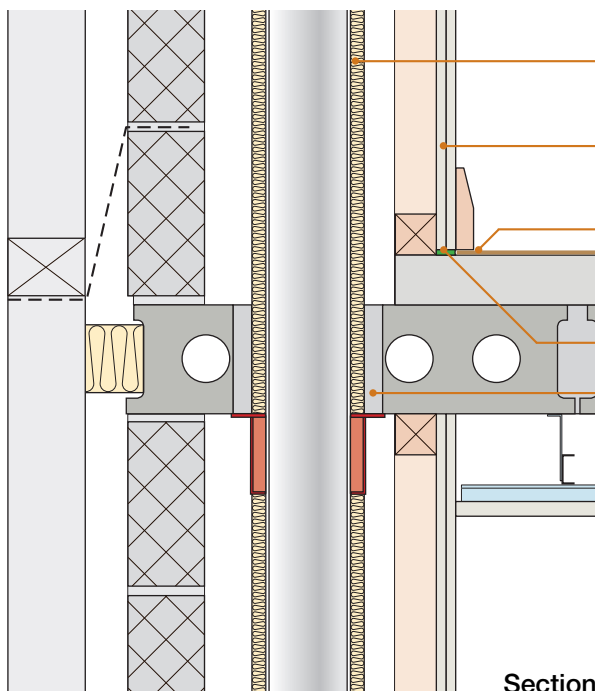

- 25mm (min) mineral wool quilt (min 10kg/m<sup>3</sup>) around pipe
- Pipe boxed in with two layers gypsum-based board, each layer nominal 8 kg/m<sup>2</sup>
- 3mm IsoRubber Top or IsoRubber FR installed over whole floor area and between skirting and screed
- Remaining gap may be sealed with mastic
- All voids around pipe sealed

### Alternative detail

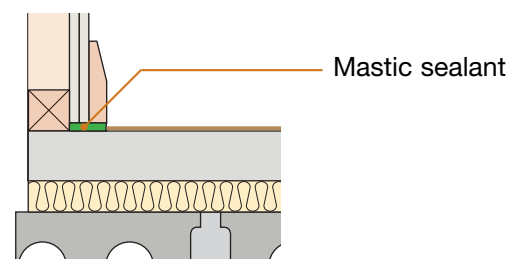

Sketch shows CT0 type ceiling treatment

blank page  
See overleaf for checklist

## CHECKLIST (to be completed by site manager /supervisor)

Company: \_\_\_\_\_

Site: \_\_\_\_\_

Plot: \_\_\_\_\_ Site manager/supervisor: \_\_\_\_\_

Ref.	Item	Yes (✓)	No (✓)	Inspected (initials & date)
1.	Are precast concrete planks 150mm (min) thick and of mass per unit area 300 kg/m <sup>2</sup> (min)?	<input type="checkbox"/>	<input type="checkbox"/>	<input style="width: 100%;" type="text"/>
2.	Are joints between precast concrete planks grouted and sealed?	<input type="checkbox"/>	<input type="checkbox"/>	<input style="width: 100%;" type="text"/>
3.	Are precast concrete planks built into the masonry walls?	<input type="checkbox"/>	<input type="checkbox"/>	<input style="width: 100%;" type="text"/>
4.	Is IsoBond adhesive being used?	<input type="checkbox"/>	<input type="checkbox"/>	<input style="width: 100%;" type="text"/>
5.	Is the IsoRubber Top or IsoRubber FR fully covering and fully bonded to the screed?	<input type="checkbox"/>	<input type="checkbox"/>	<input style="width: 100%;" type="text"/>
6.	Are the skirting boards isolated from the screed by the resilient floor cover or flexible sealant?	<input type="checkbox"/>	<input type="checkbox"/>	<input style="width: 100%;" type="text"/>
7.	Is the correct ceiling type being used for precast concrete plank thickness?	<input type="checkbox"/>	<input type="checkbox"/>	<input style="width: 100%;" type="text"/>
8.	Are all ceiling board joints sealed with tape or caulked with sealant?	<input type="checkbox"/>	<input type="checkbox"/>	<input style="width: 100%;" type="text"/>
9.	Are service pipes wrapped in quilt and boxed in with two layers of nominal 8 kg/m <sup>2</sup> gypsum-based board?	<input type="checkbox"/>	<input type="checkbox"/>	<input style="width: 100%;" type="text"/>
10.	Is separating floor satisfactorily complete?	<input type="checkbox"/>	<input type="checkbox"/>	<input style="width: 100%;" type="text"/>

Contact details for technical assistance from Thermal Economics, manufacturer of IsoRubber Top and IsoRubber FR:  
**Telephone: 01582 544255      Fax: 01582 429305      E-mail: [technical@thermal-economics.co.uk](mailto:technical@thermal-economics.co.uk)**

**Notes** (include details of any corrective action)

Site manager/supervisor signature .....

© UK registered trade mark no. 2291665  
 © Robust Details Limited 2011. All rights reserved. No part of this Handbook (other than the checklists) may be reproduced in any material form or issued or communicated to the public (including photocopying or storing it in any medium by electronic means, and whether or not transiently or incidentally to some other use of this Handbook) without the prior written permission of Robust Details Limited except in accordance with the provisions of the Copyright, Designs and Patents Act 1988.  
 Warning: the doing of an unauthorised act in relation to a copyright work may result in both a civil claim for damages and criminal prosecution.



3mm Thermal Economics IsoRubber Top or IsoRubber FR ■  
 In-situ concrete slab ■

For use in loadbearing masonry or reinforced concrete frame construction ■

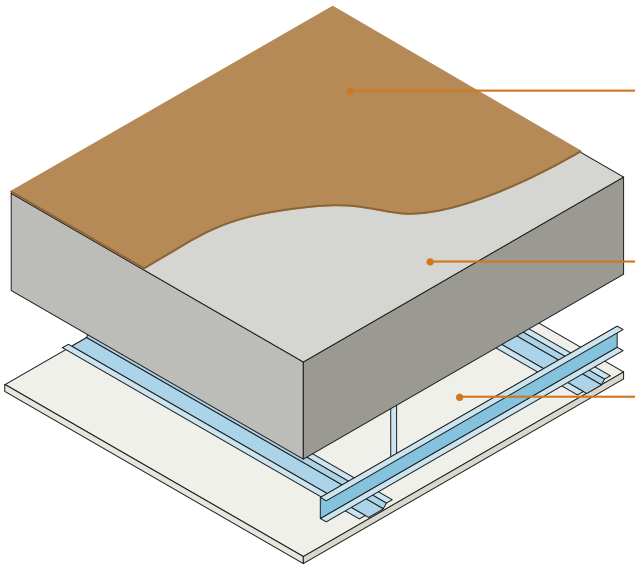

Floor covering	3mm IsoRubber Top or IsoRubber FR bonded to slab with IsoBond adhesive
Structural floor	175mm (min) in-situ concrete floor slab 2400 kg/m <sup>3</sup> (min) density
Ceiling	See section 4 for suitable ceiling treatment

## Reinforced concrete frame construction – alternative external (flanking) wall construction

Storey height glazing units are an acceptable alternative to the cavity walls illustrated:

- glazing units should not be continuous between storeys
- mullion or transom supports/framing should not be continuous between dwellings
- Refer to Appendix A

### Note:

Apartments may be built with **robustdetails**<sup>®</sup> cavity masonry separating walls (refer to Table 3a of the Introduction) provided floor slab is **NOT** continuous between dwellings

## DO

- Ensure floor slab density is 2400 kg/m<sup>3</sup> (min)
- Fill all voids between walls and floor
- Ensure IsoRubber Top or IsoRubber FR is fully bonded to slab with IsoBond adhesive
- Ensure IsoRubber Top or IsoRubber FR fully covers floor surface
- Make sure there is a ceiling void of 150mm (min) and ceiling treatment is installed in accordance with the manufacturer's instructions (where applicable)
- Ensure that floor slab breaks the vertical continuity of flanking walls
- Ensure that concrete does not enter the cavity and bridge the two leaves of supporting wall blockwork – it is acceptable to use proprietary cavity stops to provide a shutter
- Refer to Appendix A

## 1. External (flanking) wall junction – loadbearing masonry construction

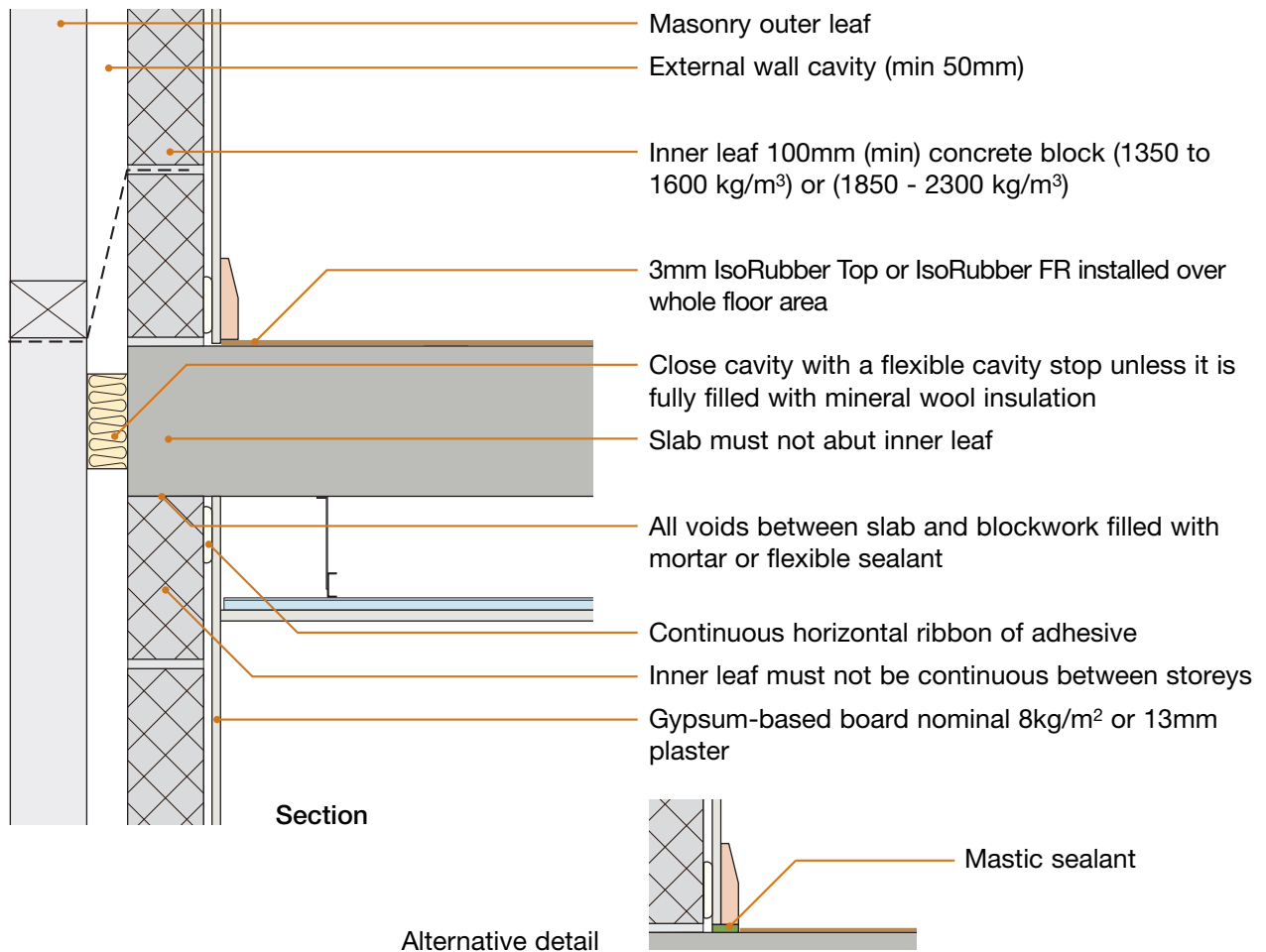

## 2. External (flanking) wall junction – reinforced concrete frame construction with steel or timber frame inner leaf

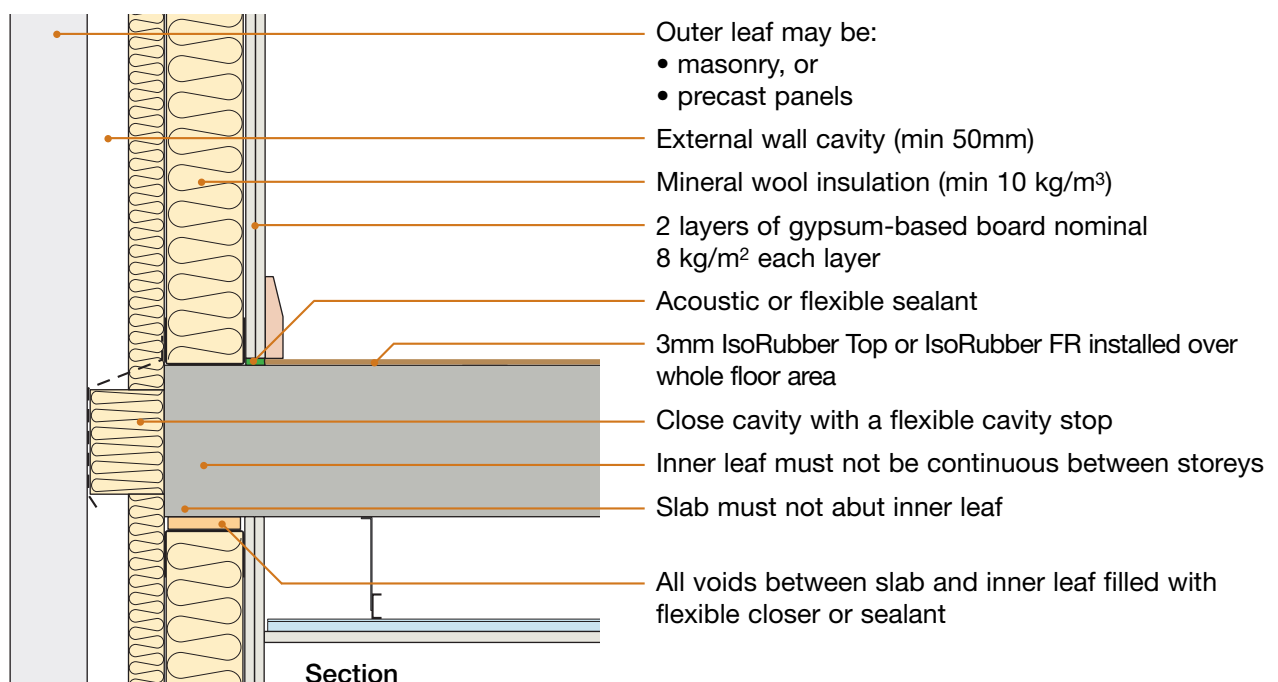

## 3. External (flanking) wall junction – reinforced concrete frame construction

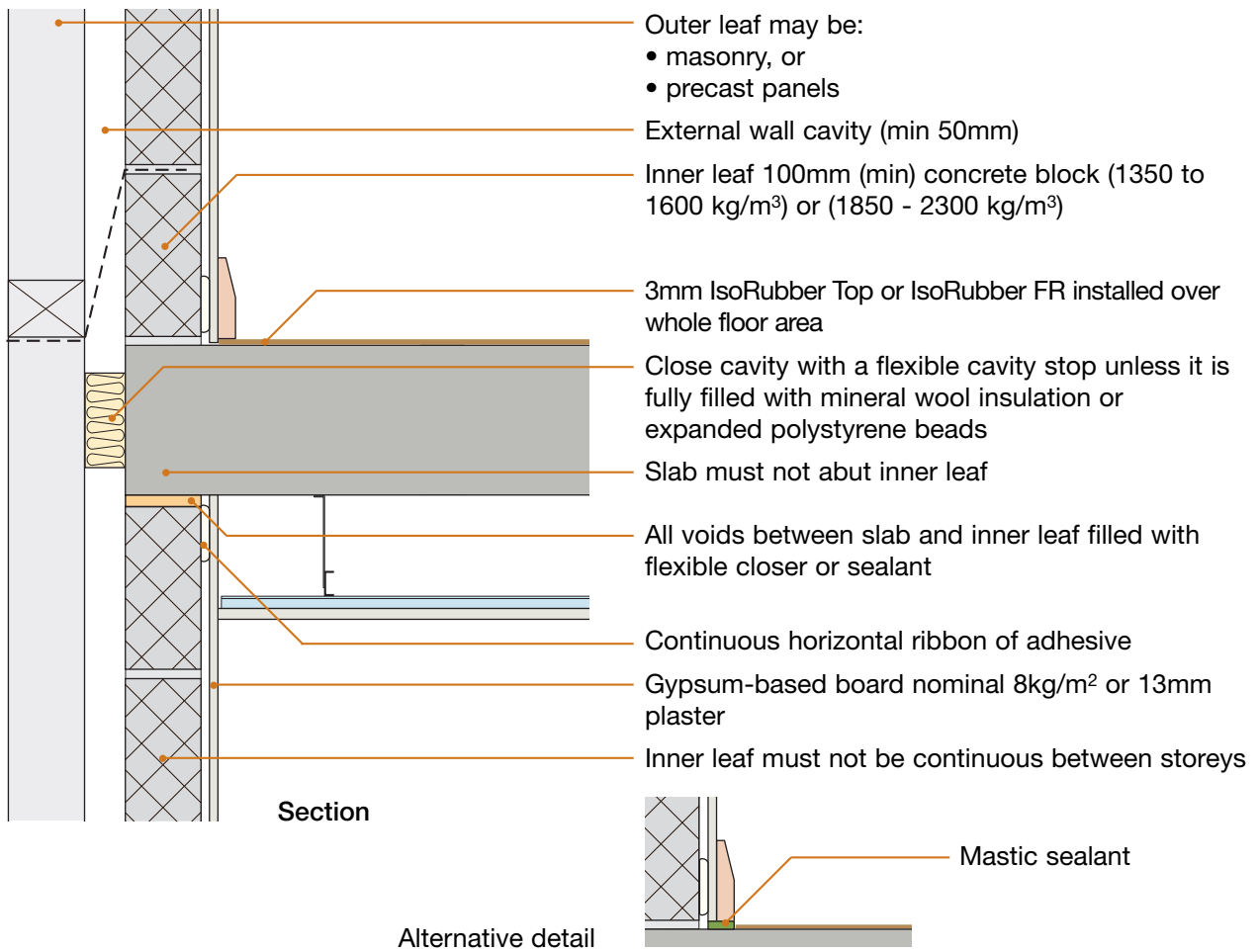

## 4. Separating wall junction – loadbearing masonry construction

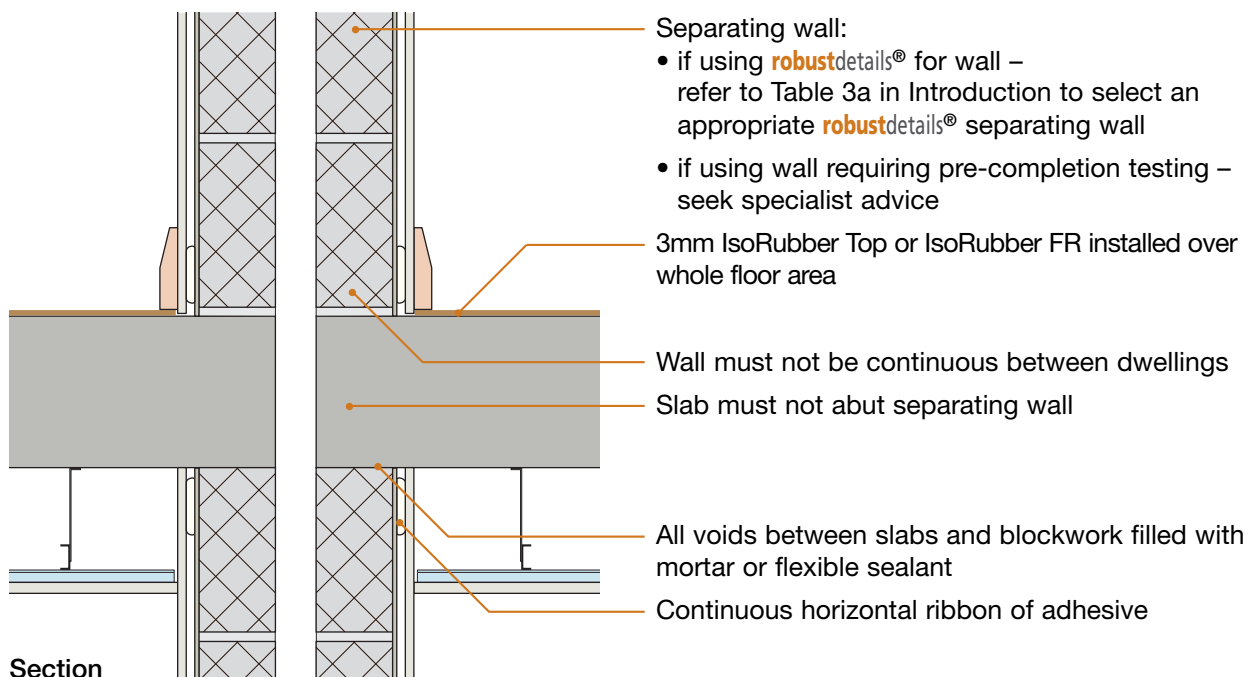

## 5. Ceiling treatment for E-FC-10

Ceiling treatment must be installed in accordance with the manufacturer's instructions.

All ceiling joints must be sealed with tape or caulked with sealant.

The maximum load on resilient bars shall not exceed that specified in the manufacturer's instructions.

Note: the sound insulation performance of ceiling treatment is increased if:

- 25mm (min) mineral wool quilt is placed in the ceiling void, and/or
- resilient hangers are used

### Downlighters and recessed lighting

Provided there is a minimum ceiling void of 150mm, downlighters or recessed lighting may be installed in the ceiling:

- in accordance with the manufacturer's instructions
- at no more than one light per 2m<sup>2</sup> of ceiling area in each room or see Appendix F
- at centres not less than 0.75m
- into openings not exceeding 100mm diameter or 100x100mm

Particular attention should also be paid to Building Regulations Part B - Fire Safety

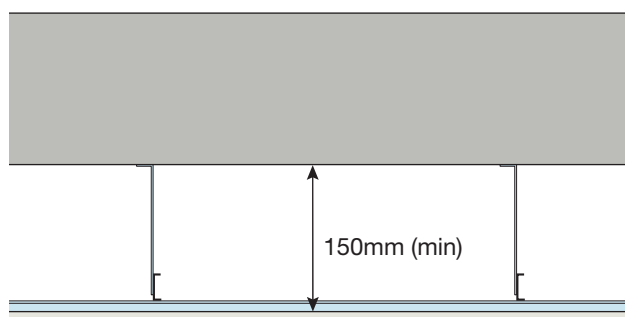

### Any ceiling system – 150mm void

- any metal ceiling system providing 150mm (min) ceiling void
- one layer of nominal 10 kg/m<sup>2</sup> gypsum-based board

## 6. Underfloor heating systems within screeds

Underfloor heating systems may be installed within the screed.

Appropriate screed depth cover to the heating system must be designed for – contact underfloor heating manufacturer for guidance.

**Note:** If required it is permissible to have an insulation layer between screed and slab (as shown in Option B).

### OPTION A

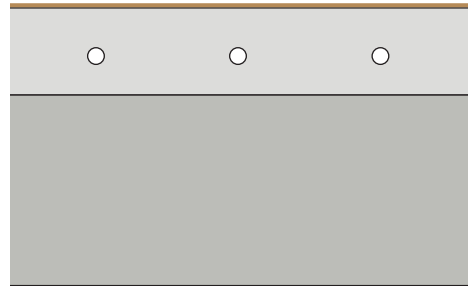

### OPTION B

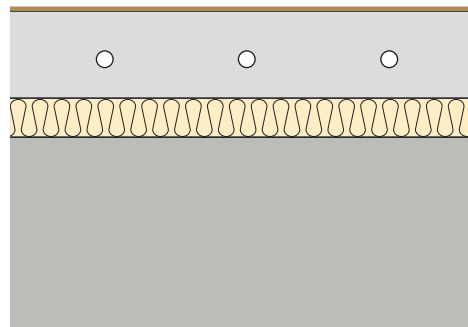

## 7. Services – Service pipes through separating floor

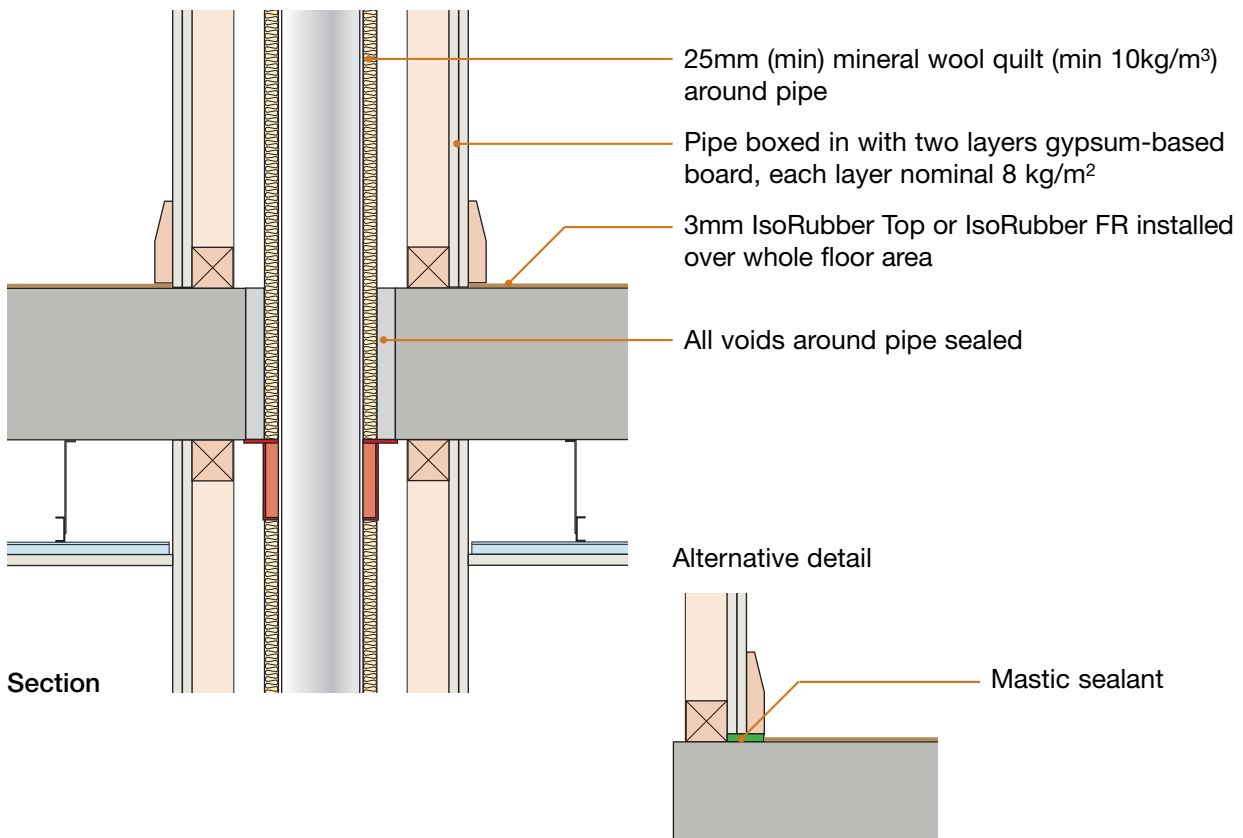

## CHECKLIST (to be completed by site manager /supervisor)

Company: \_\_\_\_\_

Site: \_\_\_\_\_

Plot: \_\_\_\_\_ Site manager/supervisor: \_\_\_\_\_

Ref.	Item	Yes (✓)	No (✓)	Inspected (initials & date)
1.	Is concrete slab density 2400 kg/m <sup>3</sup> (min)?	<input type="checkbox"/>	<input type="checkbox"/>	<input style="width: 100%;" type="text"/>
2.	Where blockwork inner leaves are adopted for the external (flanking) walls are they of the correct density?	<input type="checkbox"/>	<input type="checkbox"/>	<input style="width: 100%;" type="text"/>
3.	Is concrete slab 175mm (min) thick?	<input type="checkbox"/>	<input type="checkbox"/>	<input style="width: 100%;" type="text"/>
4.	Is inner leaf discontinuous between storeys?	<input type="checkbox"/>	<input type="checkbox"/>	<input style="width: 100%;" type="text"/>
5.	Has ceiling system been installed in accordance with the manufacturer’s instructions (where applicable)?	<input type="checkbox"/>	<input type="checkbox"/>	<input style="width: 100%;" type="text"/>
6.	Is there a minimum ceiling void of 150mm?	<input type="checkbox"/>	<input type="checkbox"/>	<input style="width: 100%;" type="text"/>
7.	Are all ceiling board joints sealed with tape or caulked with sealant?	<input type="checkbox"/>	<input type="checkbox"/>	<input style="width: 100%;" type="text"/>
8.	Has the IsoRubber Top or IsoRubber FR been bonded to the slab with IsoBond adhesive?	<input type="checkbox"/>	<input type="checkbox"/>	<input style="width: 100%;" type="text"/>
9.	Is the IsoRubber Top or IsoRubber FR fully covering the floor surface?	<input type="checkbox"/>	<input type="checkbox"/>	<input style="width: 100%;" type="text"/>
10.	Are service pipes wrapped in quilt and boxed in with two layers of gypsum-based board, nominal 8 kg/m <sup>2</sup> each layer	<input type="checkbox"/>	<input type="checkbox"/>	<input style="width: 100%;" type="text"/>
11.	Is separating floor satisfactorily complete?	<input type="checkbox"/>	<input type="checkbox"/>	<input style="width: 100%;" type="text"/>

Contact details for technical assistance from Thermal Economics, manufacturer of IsoRubber Top and IsoRubber FR:  
**Telephone: 01582 544255      Fax: 01582 429305      E-mail: [technical@thermal-economics.co.uk](mailto:technical@thermal-economics.co.uk)**

**Notes** (include details of any corrective action)

Site manager/supervisor signature .....

© UK registered trade mark no. 2291665

© Robust Details Limited 2011. All rights reserved. No part of this Handbook (other than the checklists) may be reproduced in any material form or issued or communicated to the public (including photocopying or storing it in any medium by electronic means, and whether or not transiently or incidentally to some other use of this Handbook) without the prior written permission of Robust Details Limited except in accordance with the provisions of the Copyright, Designs and Patents Act 1988.

Warning: the doing of an unauthorised act in relation to a copyright work may result in both a civil claim for damages and criminal prosecution.

# Appendix A1 – Additional Guidance

## Contents

Section	Page	
Wall ties in cavity masonry separating walls	1	<p><b>Wall ties in cavity masonry separating walls</b></p> <p>Cavity masonry separating wall Robust Details must have no greater than a type A connection of one leaf to the other. This is achieved by using wall ties specifically tested for type A status over the cavity width being built, positioned 900mm horizontally (staggered) and 450mm vertically to give 2.5 ties/m<sup>2</sup>. If a greater number of ties is required, check with the tie manufacturer that a type A connection can still be achieved.</p> <p>Special consideration should be given in respect of movement joints, where de-bonded ties should be used across the movement joint to allow fewer wall ties across the cavity (see Movement Joints section on page 2).</p> <p>Approved Document E clause 2.19 describes the requirements for Tie Type A (separating walls) as follows:</p> <p><b>Tie type A</b></p> <p>Connect the leaves of a masonry cavity wall only where necessary by butterfly ties as described in BS 1243: 1978 Metal ties for cavity wall construction, and spaced as required for structural purposes (BS 5628-3: 2001 Code of practice for use of masonry. Materials and components, design and workmanship, which limits this tie type and spacing to cavity widths of 50mm to 75mm with a minimum masonry leaf thickness of 90mm). Alternatively, use wall ties with an appropriate measured dynamic stiffness for the cavity width. The specification for wall ties of dynamic stiffness, <math>k_{xmm}</math> in MN/m with a cavity width of <math>X</math> mm and <math>n</math> ties/m<sup>2</sup> is <math>n \cdot k_{xmm} &lt; 4.8</math> MN/m<sup>3</sup>.</p> <p>When using wall ties for masonry separating walls the specifier should ensure that the wall tie manufacturer has a test report that demonstrates compliance with the required ADE criteria.</p>
Wall ties in cavity masonry external walls	1	
Cavity stops	2	
Cavity trays	2	
Movement joints in cavity masonry separating walls	2	
Bed joint reinforcement	3	
Internal floor joists/floor beams and masonry separating walls	3	
Structural steelwork in masonry separating walls	4	
Concrete beam and block ground and internal floors	4	
Coursing in blockwork separating walls	4	
Flues in separating walls	4	
Internal render and finishes	4	
Services and chases in separating walls	4	
Spandrel panels	5	
Room-in-roof - requirements for gypsum-based boards	5	
Gypsum-based board	5	
Cavity masonry separating walls – staggered external (flanking) wall junction	6	
Roof junctions – thermal insulation	6	
Building Regulations Part A (2004)	6	
Internal walls (minimum mass requirements)	6	
Junctions between internal partition walls and separating floors	6	
Subfloor ventilation	7	
Radon and methane barriers	7	
Ground floor junctions	7	
Screed thickness	7	
Precast concrete plank separating floors with steel beams	7	
Services in separating floors	8	
Underfloor heating systems in separating floors	8	
Resilient bars	9	
Timber floating floor treatments	9	
Floating floor treatments in kitchens and bathrooms	9	
Laminated or ceramic flooring on separating floors	9	
Screed floating floor treatments	9	
Masonry angle supports	9	
Full height glazing units junction with <b>robust</b> details® separating floors	9	
Specification requirements	10	
Lifting holes in cassette floors	10	
		<p><b>Wall ties in cavity masonry external walls</b></p> <p>In relation to the wall tie requirements for external walls tie “Type A” may be used if it satisfies the requirements of Building Regulation Part A – Structure. However, where tie “Type A” does not meet these requirements for external walls tie “type B” wall ties should be used.</p> <p>Approved Document E clause 2.20 describes the requirements for Tie Type B (external walls).</p>

## Appendix A1 – Additional Guidance

### Cavity stops

The flexible cavity stops at the junction of the separating wall and the external (flanking) wall are shown in the Robust Details as a single piece of material (diagram a). It is acceptable for these to be provided as two separate pieces (diagram b), or three separate pieces (diagram c).

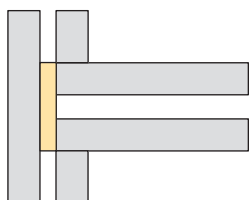

Diagram a

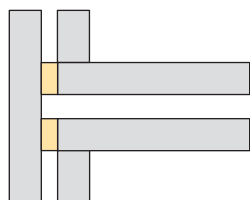

Diagram b

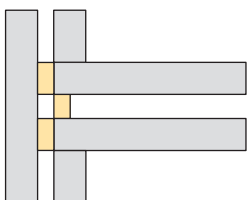

Diagram c

The following types of cavity stop may be used:

- single mineral wool batt cavity stops
- dual rigid cavity stops on either side of the external wall cavity (not for masonry separating walls)
- single rigid cavity stop attached to one leaf of the separating wall only (not for masonry separating walls)
- flexible single cavity stop such as the mineral wool “tubular style”
- flexible double cavity stops such as the mineral wool “tubular style” where one is fitted in line with each leaf of the separating wall.

Single rigid cavity stops which structurally couple both leaves of the separating wall are not permitted.

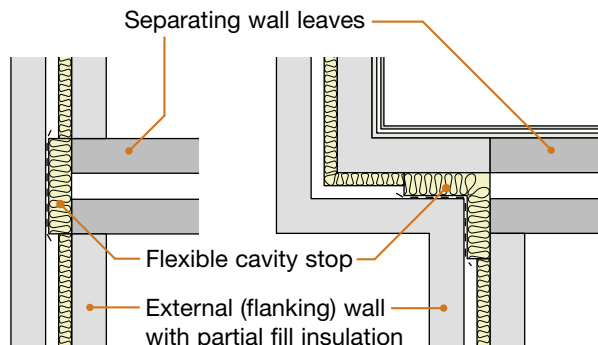

Diagram d

Partial fill insulation should be installed up to the cavity stop.

### Cavity trays

The cavity trays shown above the cavity stops are included for illustrative purposes only and not for acoustic reasons.

### Movement joints in cavity masonry separating walls

#### Separating walls with a gypsum-based board finish

Where possible, movement joints should be avoided in separating walls with a gypsum-based board finish. Where they are essential, they should be formed as follows:

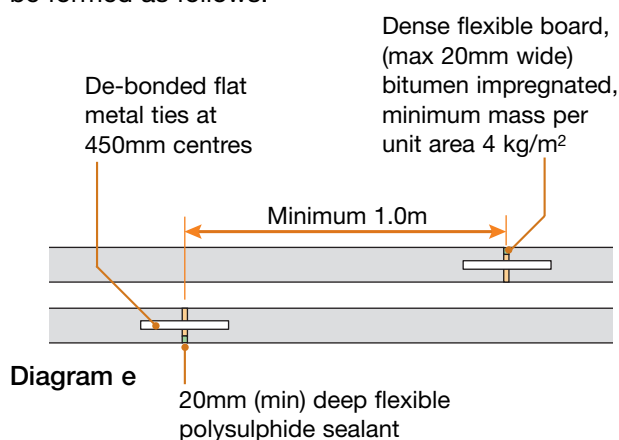

Diagram e

Where possible, movement joints should be located in bathrooms or other minor rooms or behind cupboards, etc.

#### Separating walls with wet plaster finish

Movement joints are not acceptable in **robustdetails**<sup>®</sup> separating walls with a wet plaster finish unless they are strategically placed behind internal wall junctions or service pipe casings.

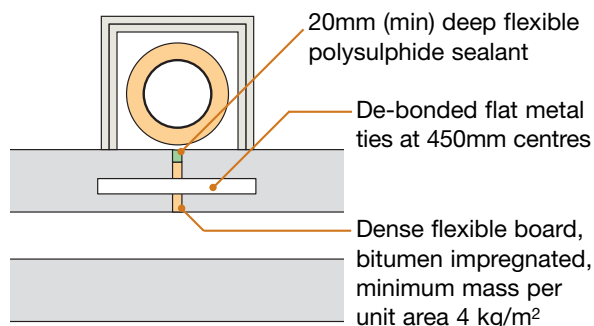

Diagram f

The movement joints must also be staggered and spaced not less than 1m apart, as shown in Diagram d above.



## Appendix A1 – Additional Guidance

### Bed joint reinforcement

It is acceptable to install masonry reinforcement within the horizontal bed joints of the cavity masonry separating provided:

- the masonry reinforcement is contained wholly within the mortar bed joint of each individual leaf of masonry
- the masonry reinforcement does not connect the two leaves of the cavity walls together or bridge the cavity in any way

### Internal floor joists/floor beams and masonry separating walls

Internal floor joists at right angles to the separating wall may be supported by metal joist hangers or be built into the wall.

The acoustic performance of separating walls is adversely affected by any gaps in the masonry as these provide a direct sound transmission path.

**It is essential that joists and beams are built in only if a high standard of workmanship can be guaranteed.**

#### *Solid timber joists*

Solid timber joists may be built into the separating wall, provided that:

- the mortar joints around each joist perimeter are recessed or struck, and
- the joint between the masonry and the timber is carefully pointed with silicone sealant.

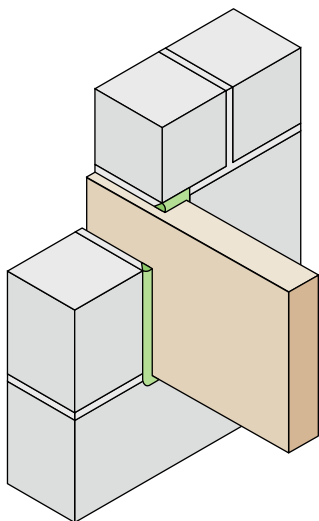

Alternatively, proprietary joist caps/ends designed to satisfy the air leakage requirements of Approved Document L1 may be used. They should be installed in accordance with the manufacturer's instructions.

In circumstances where the joist end cap is larger than the depth of the joist, such that there is a gap between the top of the joist and the joist end cap, this should be filled with mineral wool or other suitable material such that the acoustic performance of the wall is maintained.

#### *Metal web joists*

Metal web joists may be built into the separating wall following the guidance for solid timber joists above. Metal web joists must have solid ends.

#### *Timber I-Joists*

Timber I-joists may be built into the separating wall, provided that:

- proprietary filler pieces are fitted on both sides of the web between the top and bottom flanges. These filler pieces must not damage the joist flanges - their depth should be slightly less than the dimension between the joist flanges to achieve a "loose fit".
- the mortar joints around each joist perimeter are recessed or struck, and
- the joint between the masonry and the timber and any other air paths are carefully pointed with silicone sealant.

Alternatively, proprietary joist caps/ends designed to satisfy the air leakage requirements of Approved Document L1 may be used. They should be

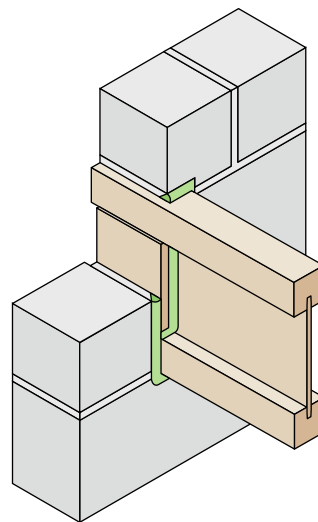

installed in accordance with the manufacturer's instructions. In circumstances where the joist end cap is larger than the depth of the joist, such that there is a gap between the top of the joist and the joist end cap, this should be filled with mineral wool or other suitable material such that the acoustic performance of the wall is maintained.

## Appendix A1 – Additional Guidance

### Steel beams

Steel beams may be built into the leaf of a cavity separating wall, provided that all voids around the beam ends are filled with mortar or flexible sealant.

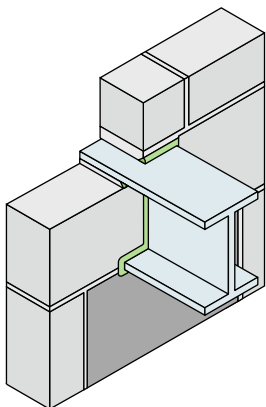

Separating walls should not be constructed off steel beams.

### Structural steelwork in masonry separating walls

Steel columns built into masonry separating walls are not permitted.

Separating walls should not be constructed off steel beams.

### Concrete beam and block ground and internal floors

Concrete beam and block floors may be built into the separating wall, provided:

- all voids are carefully filled with mortar
- the floor does not bridge the cavity leaves.

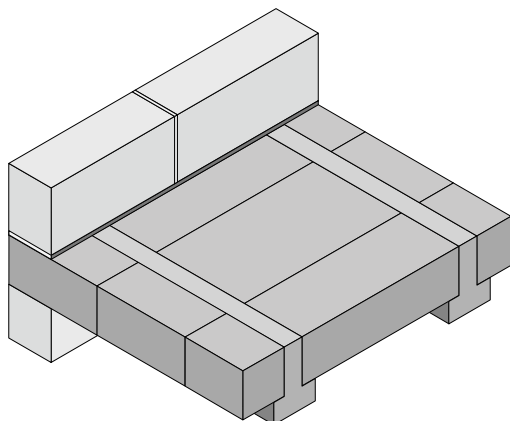

### Coursing in blockwork separating walls

For the purposes of adjusting coursing it is permissible to use smaller units of **robustdetails**® separating wall material (e.g. brick sized), provided the density of the smaller units is at least the same as the separating wall material.

### Flues in separating walls

Flue blocks may not be built into the separating wall where the finish is wet plaster. Flue blocks may only be built into the normal width of a separating wall where a diagram is included in the Robust Details.

Any of the **robustdetails**® masonry separating walls with gypsum-based board on dabs finish, may use the following alternative detail:

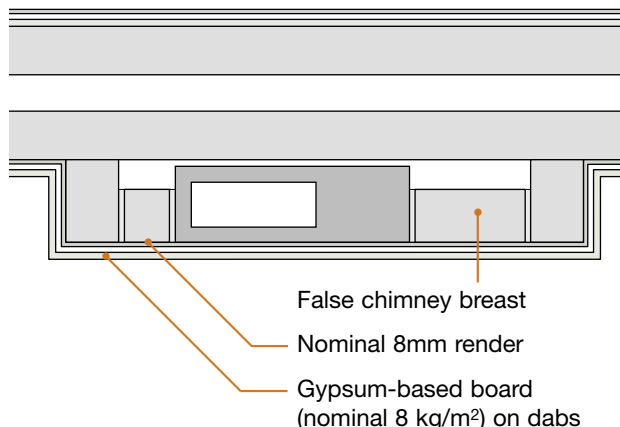

### Internal render and finishes

Some of the Robust Details for masonry separating walls indicate the use of an internal render (parge) coat prior to the application of dry lining. Where a cement:sand render coat is used it should not be float or skim finished but preferably applied in an uneven manner with a trowel (or equivalent) and scratch finished.

Mixes quoted are for cement, lime and sand by volume based on damp sand. Mixes made with cement, sand and plasticiser are also acceptable.

Internal render, gypsum-based board and wet plaster may be omitted from the following locations:

- wall surfaces not facing into a room
- floor joist/beam zone
- roof space (where there are no rooms in the roof)
- staircases may be installed prior to the application of render, and the gypsum-based board or wet plaster are not required behind the stair string.

### Services and chases in separating walls

Where possible, services should not be built into the separating wall.

However, where chasing is permitted in the Detail, they should be kept to a minimum. Chases must not be located back to back. Care must be taken to ensure all voids are fully filled with mortar. Where conduits or cappings are used they should not be in contact with the gypsum-based board.

The Robust Details for timber and steel framed walls show how services should be built in.

## Appendix A2 – Specific Flanking Conditions

Smartroof complete “room-in-roof” panel system using **robustdetails**® timber or masonry cavity walls. Refer to Table 6 in Introduction.

### 1. Gable flanking junction – masonry

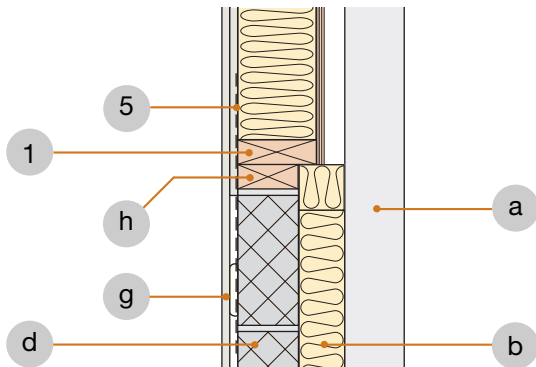

### 2. Room-in-roof junction with masonry cavity walls

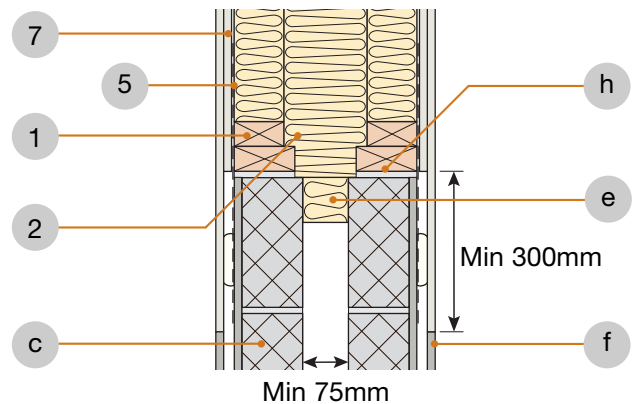

### 3. Gable flanking junction – timber frame

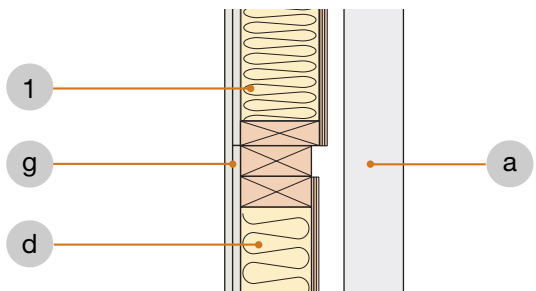

### 4. Room-in-roof junction with timber frame cavity walls

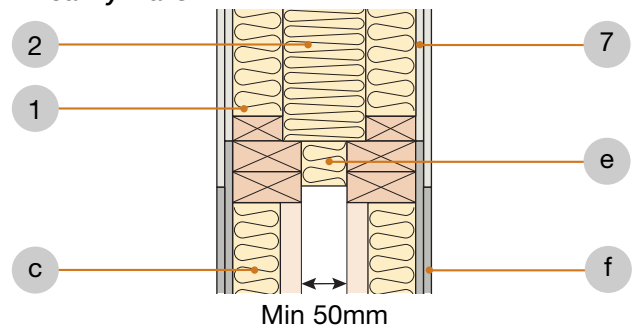

#### Key

- 1 Smartroof panel.
- 2 Breather membrane-encased insulation cushion, fully filling the cavity.
- 3 Smartroof roof panel.
- 4 125x265mm flexible cavity closer by Smartroof.
- 5 Vertical metal straps by Smartroof.
- 6 25x50mm counterbattens by Smartroof.
- 7 2 layers min.12.5mm gypsum-based board total 19.6 kg/m<sup>2</sup> to cover spandrel and wall plate second layer to overlap masonry by min.300mm.
- a Outer leaf of external wall.
- b Continue cavity batts up to gable end if required.
- c Refer to relevant **robustdetails**® separating wall.
- d Inner leaf dependent on Robust Detail being used.
- e Flexible cavity closer.
- f Gypsum-based board(s) as specified on **robustdetails**® separating wall.
- g Gypsum-based board nominal 8 kg/m<sup>2</sup>. 2 layers required where separating floors are used (refer to **robustdetails**® separating floor).
- h 100x50mm wall plate on nominal 10mm mortar bed. Ensure no gaps remain.

### 5. Separating wall – roof junction

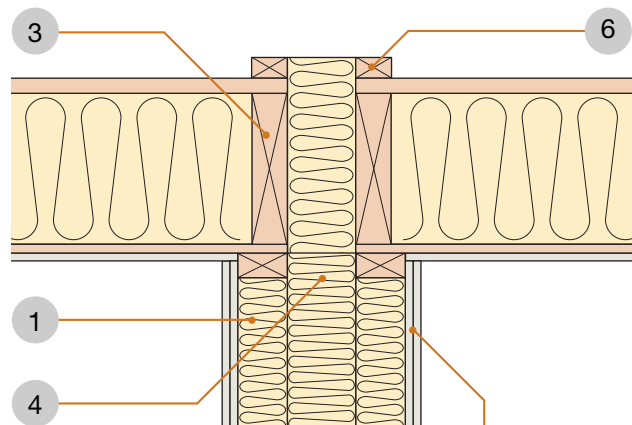

(In apex void) 2 layers of 12.5mm gypsum-based board nominal 19.6 kg/m<sup>2</sup>

Contact details for Smartroof Limited:

**Telephone: 01283 200 199**  
**E-mail: [info@smartroof.co.uk](mailto:info@smartroof.co.uk)**  
**Web: [www.smartroof.co.uk](http://www.smartroof.co.uk)**

## Appendix A2 – Specific Flanking Conditions

Kingspan TEK inner leaf flanking condition for **robustdetails**<sup>®</sup> timber separating walls. Refer to Table 6 in Introduction. *Currently when used with separating floors in apartments, separating floors will require pre-completion testing.*

### 1. External (flanking) wall junction

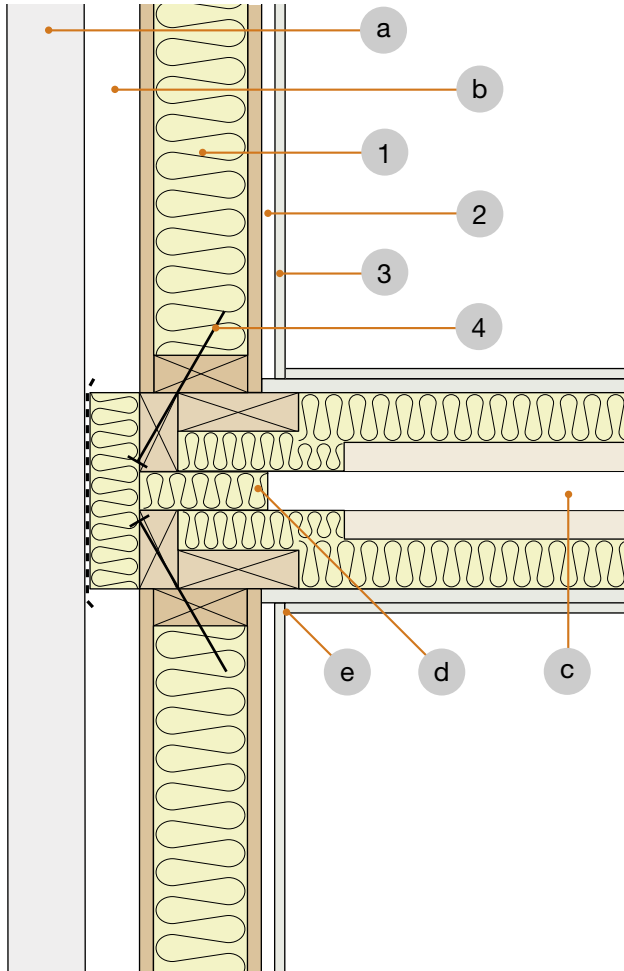

### 2. Staggered external (flanking) wall junction

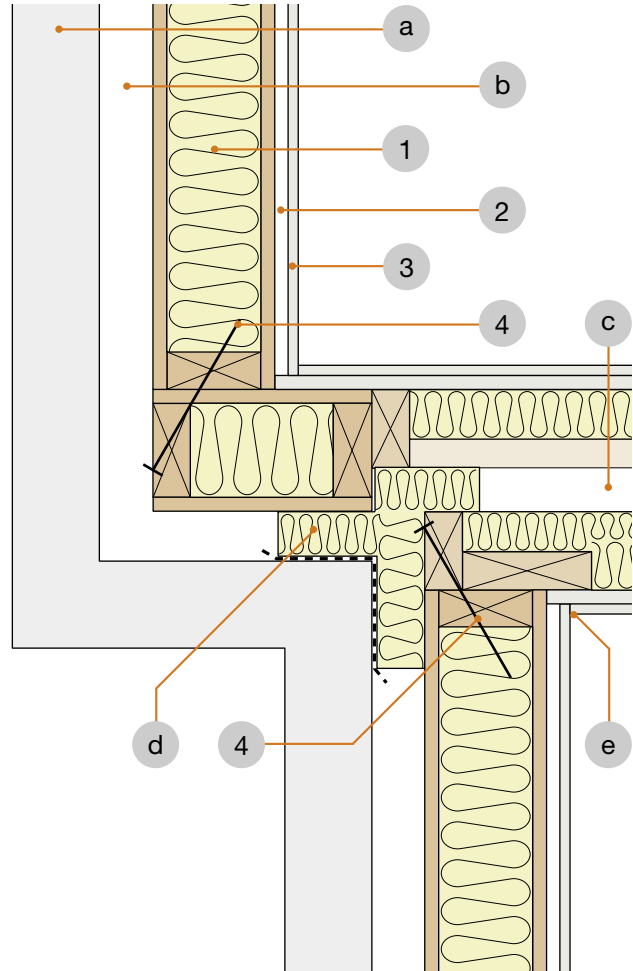

#### Key

- 1 Kingspan TEK – 142 Panel.
- 2 Service void (if required).
- 3 One layer of gypsum-based board nominal 8 kg/m<sup>2</sup> on inner leaf where there is no separating floor, e.g. for houses.  
Two layers of gypsum-based board nominal 8 kg/m<sup>2</sup> each on inner leaf where there is a separating floor (non-**robustdetails**<sup>®</sup> floor), e.g. for flats and apartments.
- 4 Approved fixings to TEK BBA Cert No. 02/S029.

- a Masonry outer leaf (min 100mm thick).
- b External wall cavity (min 50mm).
- c **robustdetails**<sup>®</sup> timber frame separating wall. (Refer to Table 6 in Introduction and relevant timber frame Robust Details in Handbook).
- d Close cavity with flexible cavity stop (see Appendix A).
- e Seal all joints with tape or caulk with sealant.

Contact details for Kingspan TEK,  
Kingspan Insulation Limited:

**Telephone: 01544 387382**

**Fax: 01544 387482**

**E-mail: [technical.uk@tek.kingspan.com](mailto:technical.uk@tek.kingspan.com)**

**Web: [www.tek.kingspan.com](http://www.tek.kingspan.com)**

## Appendix A2 – Specific Flanking Conditions

RoofSpace I-Roof™ “room-in-roof” panel system using **robustdetails**® timber or masonry cavity walls. Refer to Table 6 in Introduction.

### 1. Room-in-roof junction with timber frame cavity walls

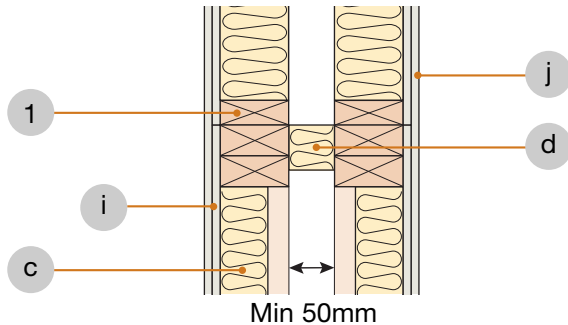

### 2. Room-in-roof junction with masonry cavity walls

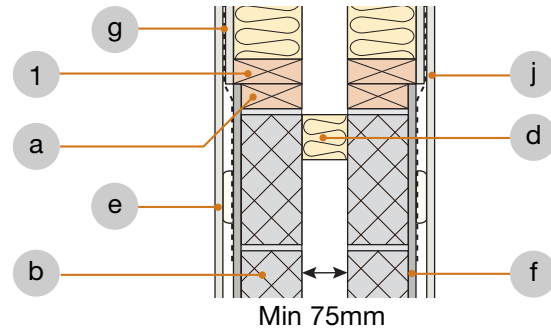

### 3. Separating wall – roof junction

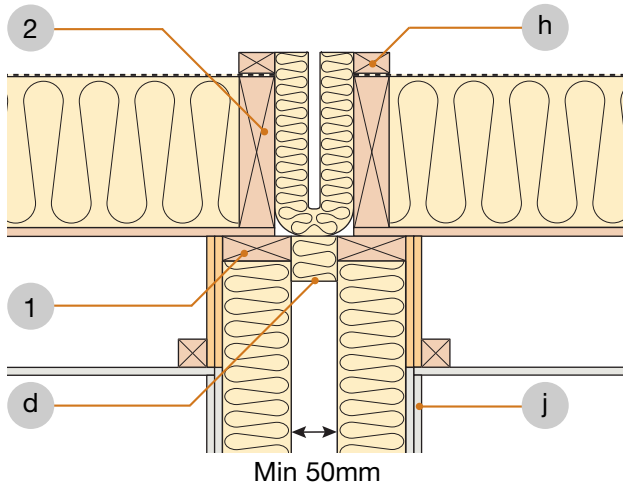

### 4. Internal floor cassette junction option

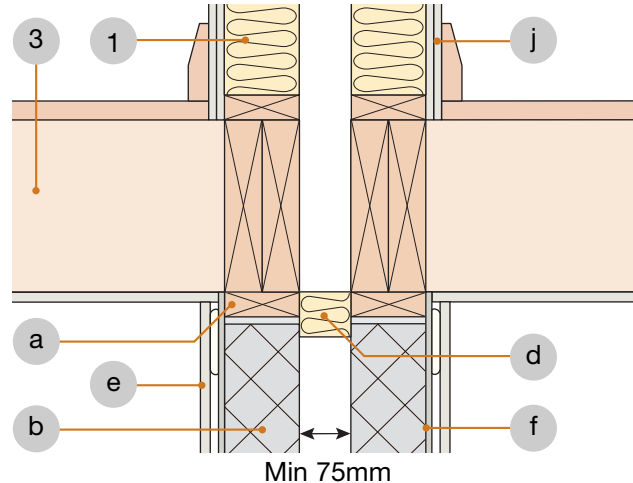

#### Key

- 1 RoofSpace I-Roof™ spandrel panel.
- 2 RoofSpace I-Roof™ roof panel.
- 3 RoofSpace internal floor cassette.
- a Timber wall plate bedded on 10mm mortar bed to take out unevenness in blockwork.
- b Minimum 100mm blockwork.
- c Timber frame separating wall leaf.
- d Cavity closer.
- e Gypsum-based board dependent on Robust Detail being used.
- f Nominal 8mm render coat (refer to relevant **robustdetails**® separating wall).
- g Vertical metal straps at 1200mm centres if required.
- h 25 x 38mm counterbatten.
- i 2 layers gypsum-based board total nominal 22 kg/m<sup>2</sup>.
- j 2 layers gypsum-based board total minimum 19.6 kg/m<sup>2</sup>.

### 5. Separating wall – roof junction – stepped terrace

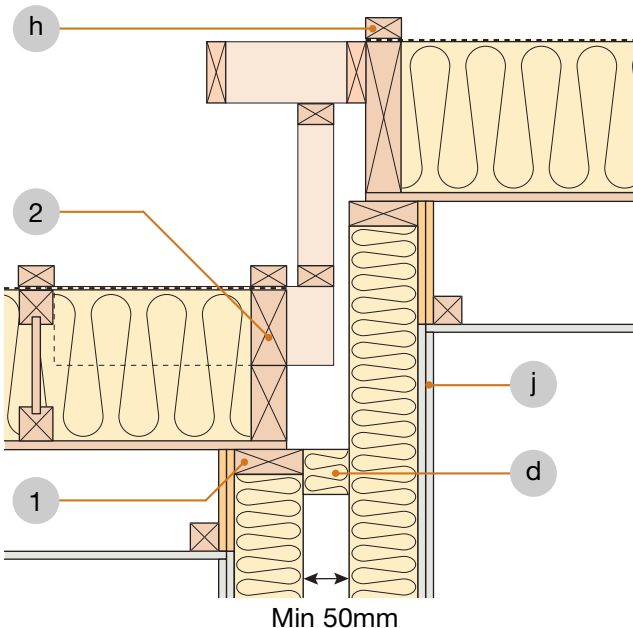

#### Spandrel panel cavity insulation (optional)

The cavity between the spandrel panels may be insulated with mineral wool rolls or batts with a density of 18-40 kg/m<sup>3</sup>. Ensure insulation thickness is no greater than 10mm wider than cavity width to avoid excessive compression of the insulation.

Contact details for Roofspace Solutions:

**Telephone: 01789 768000**

**E-mail: [technical@roofspacesolutions.co.uk](mailto:technical@roofspacesolutions.co.uk)**

**Web: [www.roofspacesolutions.co.uk](http://www.roofspacesolutions.co.uk)**

## Appendix A2 – Specific Flanking Conditions

Space4 “room-in-roof” panel system using **robustdetails**<sup>®</sup> timber or masonry cavity walls. Refer to Table 6 in Introduction.

### 1. Non room-in-roof spandrel panel to timber separating wall junction

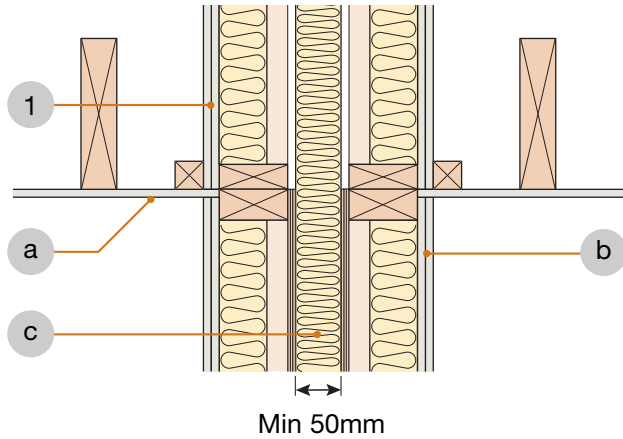

### 2. Spandrel panel to masonry separating wall junction

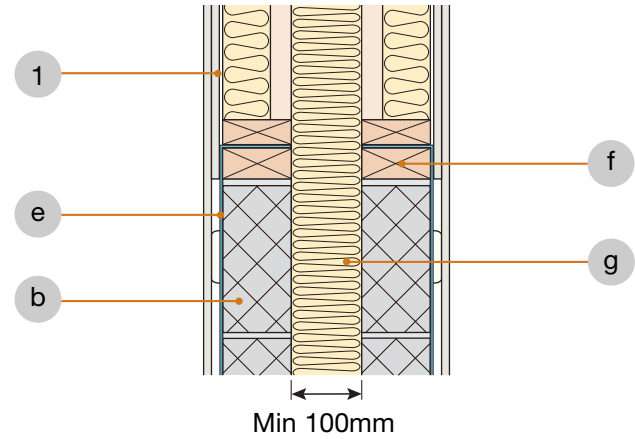

### 3. Roof cassette to timber separating wall junction for room-in-roof

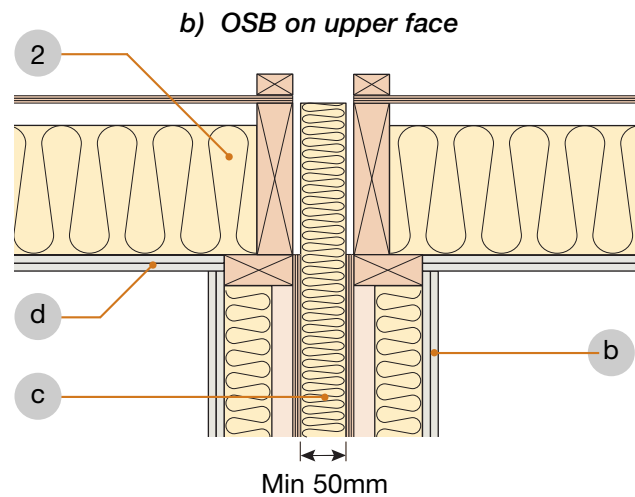
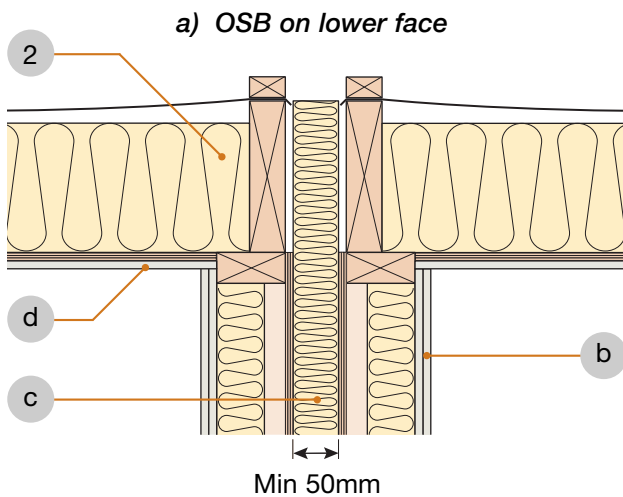

#### Key

- 1 Space4 spandrel panel.
- 2 Space4 roof cassette.
- a Minimum 1 layer nominal 8 kg/m<sup>2</sup> gypsum-based board to ceiling.
- b **robustdetails**<sup>®</sup> separating wall.
- c Mineral wool 18-40 kg/m<sup>3</sup>.
- d OSB underdraw overlaid with minimum 1 layer gypsum-based board nominal 16 kg/m<sup>2</sup> total or 2 layers of gypsum-based board nominal 16 kg/m<sup>2</sup> total.
- e Vertical metal straps at 1200mm centres if required.
- f Wall plate fully bedded on mortar with no gaps.
- g Mineral wool 12-25 kg/m<sup>3</sup>.

### 4. Internal floor junction for room-in-roof

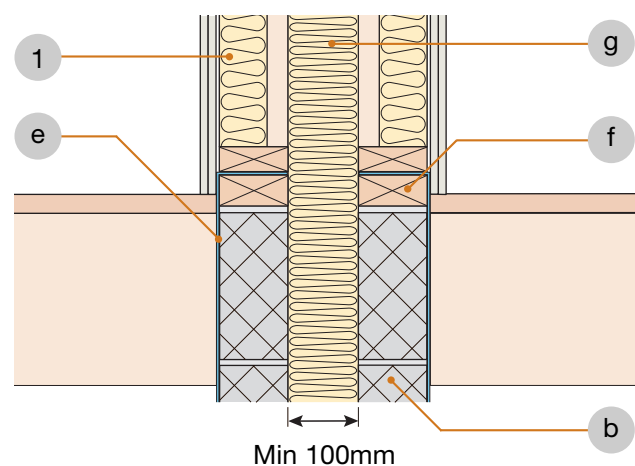

Contact details for Space4:

**Telephone: 0121 748 8383**  
**Fax: 0121 776 7369**  
**E-mail: [technical@space4.co.uk](mailto:technical@space4.co.uk)**  
**Web: [www.space4.co.uk](http://www.space4.co.uk)**

# Appendix A2 – Specific Flanking Conditions

## Section A - cavity walls

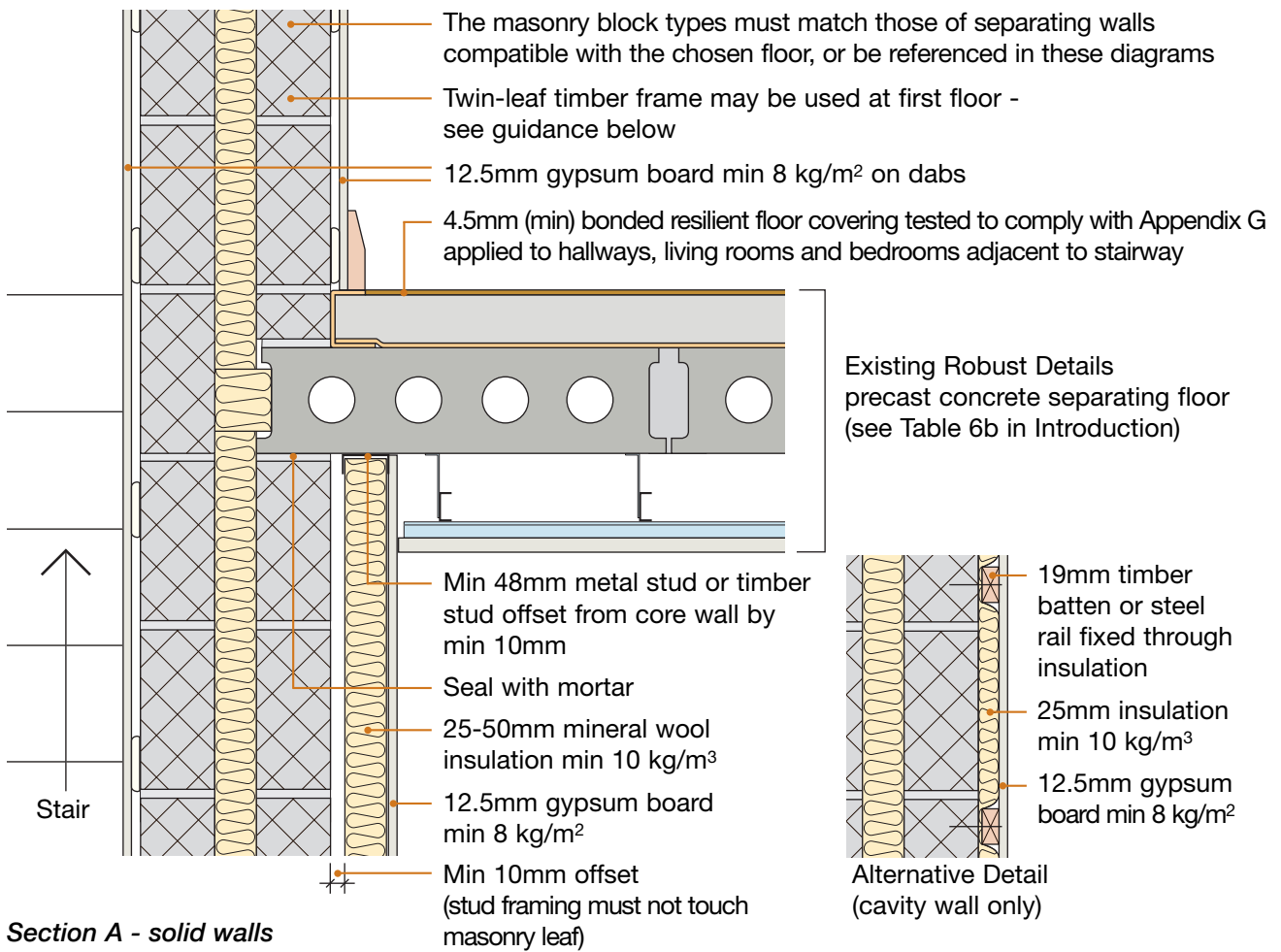

## Section A - solid walls

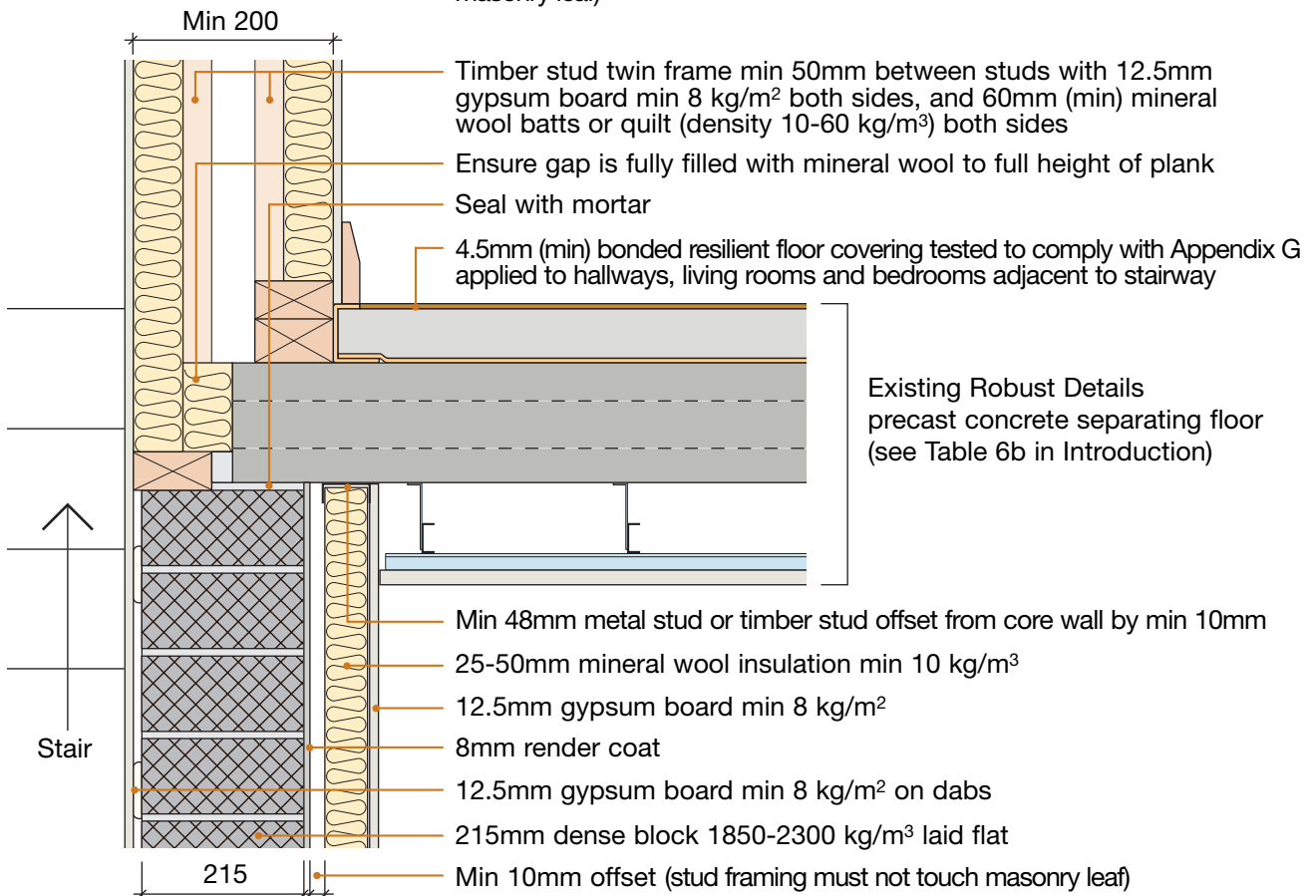

# Appendix A2 – Specific Flanking Conditions

**Section B - common junctions at stair landing**  
**Timber stairs**

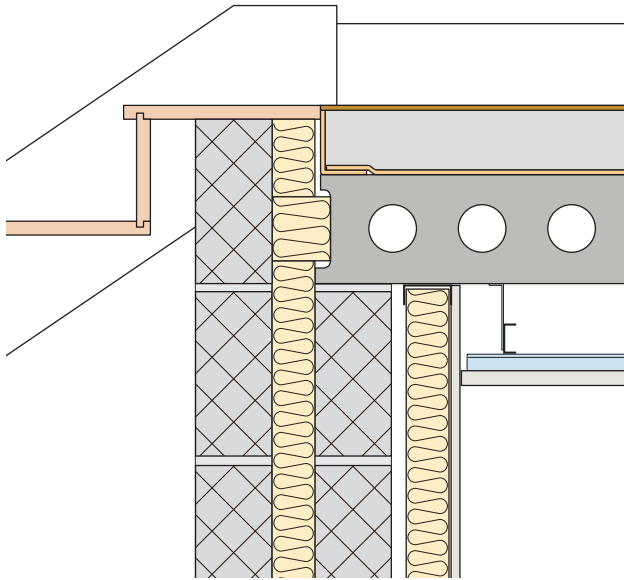

Joint filled and sealed with grout or mortar

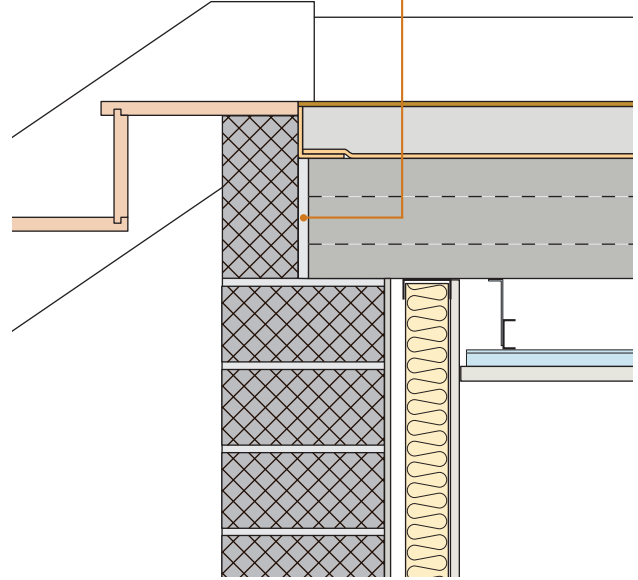

**Section B - common junctions at stair landing**  
**Concrete stairs**

Joint filled and sealed with grout or mortar

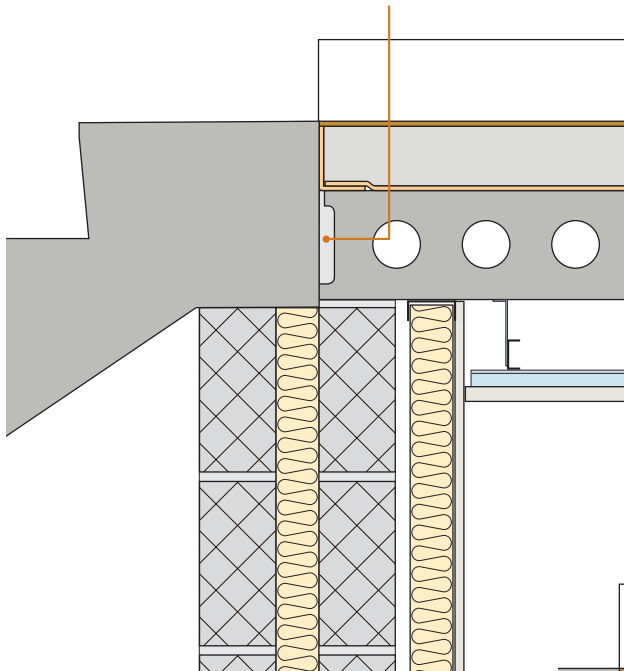

Joint filled and sealed with grout or mortar

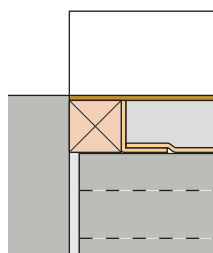
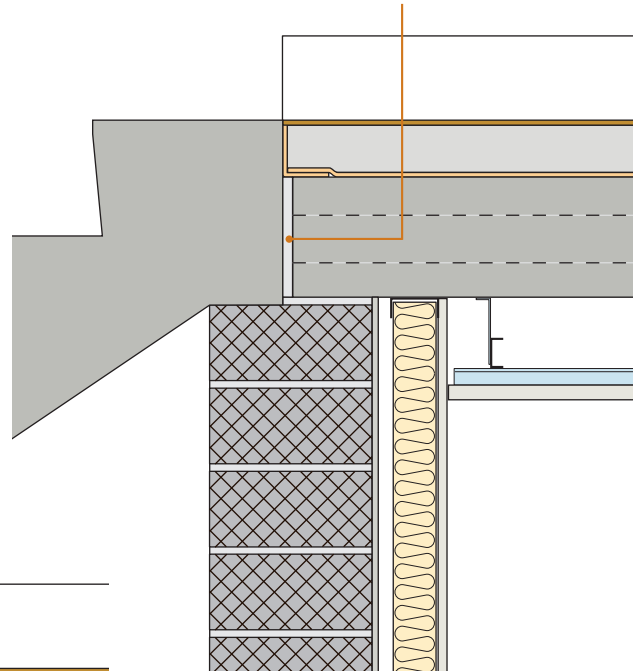

Alternative Detail at Floor/Stair Junction  
 (can be used with any of the four configurations shown above)



## Appendix B

### Glossary

The definitions given below are for the purposes of this document only and are not intended to be rigorous.

#### **Absorption**

Conversion of sound energy into heat, often by the use of a porous material.

#### **Absorbent material**

Material that absorbs sound energy.

#### **Airborne sound**

Sound propagating through the air, often linked to noise sources such as speech and television.

#### **Airborne sound insulation**

Sound insulation that reduces the transmission of airborne sound between adjoining dwellings or parts of adjoining dwellings.

#### **Block density**

The net density of the block ( $\text{kg/m}^3$ ), measured at the appropriate moisture content from Table 3.2 CIBSE Guide A (1999), necessary to achieve the required mass per unit area ( $\text{kg/m}^2$ ) of wall.

#### **Block thickness**

The block thickness quoted is the work size. Permissible manufacturing tolerances in accordance with the appropriate material part of BS EN 771.

#### **Built in insulation**

Insulation batts built in during construction (not pumped or blown material).

#### **Cavity stop**

A proprietary product or material such as mineral wool (fibre) used to close the gap in a cavity wall.

#### **Composite resilient batten**

A timber batten which is composed of a timber batten with a prebonded resilient material to provide isolation between the flooring surface layers and floor base.

#### **Cradle/Saddle**

An intermediate support system (with a resilient layer base) which uses levelling packer pieces to support a timber batten, isolating it from the floor base.

#### **$C_{tr}$**

Spectrum adaptation term (No.2) from BS EN ISO 717-1 to take account of a specific sound spectra (which are predominantly low frequency based).

#### **Decibel (dB)**

The unit used for different acoustic quantities to indicate the level with respect to a reference level.

#### **Density ( $\text{kg/m}^3$ )**

Mass per unit volume, expressed in kilograms per cubic metre ( $\text{kg/m}^3$ ).

#### **Direct transmission**

Sound which is transmitted only through the main separating element and involves no other flanking element.

#### **$D_{nT}$**

Standardised level difference. The difference in sound level between a pair of rooms (source and receiving rooms), for a stated frequency, which is corrected (normalised) for the reverberation time (in the receiving room). See BS EN ISO 140-4.

#### **$D_{nT,w}$**

Weighted standardised level difference. A single-number quantity (weighted) which characterises the airborne sound insulation between two rooms. See BS EN ISO 717-1.

#### **$D_{nT,w} + C_{tr}$**

Weighted standardised level difference which characterises the airborne sound insulation between two rooms using spectrum adaptation term (No.2) from BS EN ISO 717-1.

#### **Flanking element (e.g. flanking wall)**

Any building element that contributes to the airborne sound or impact transmission between rooms in a building which is not the direct separating element (i.e. not the separating wall or separating floor).

#### **Flanking strip or edge strip**

A 5mm (min) resilient strip which is located at the perimeter of a floor to isolate the floor surface layer from the **perimeter walls and skirtings**. A typical example of a flanking strip is 5mm (min) foamed polyethylene. Rigid boards, (such as extruded, expanded or bead polystyrene) or mineral wool based products may not be used as a flanking strip where the walking surface is board based.

For screed floating floors the permitted flanking strip or edge strip detail will be dependant on the resilient layer system adopted and the relevant Robust Detail must be strictly followed.

#### **Flanking transmission**

Airborne sound or impact transmission between rooms which is transmitted via flanking elements and/or flanking elements in conjunction with the main separating elements.

#### **Flexible closer**

A flexible cavity stop or cavity barrier typically mineral wool ‘tubular style’ which seals the air path in cavities linking adjoining dwellings.

### **Floating floor treatment**

A timber floating floor system which may use battens, cradles or platform base; all of which use a resilient layer to provide isolation from the base floor and adjacent wall elements.

### **Flooring board**

The boards which form the top surface of the floor. Boards should be wood-based panels 600mm (min) wide.

### **Habitable room**

For the purposes of Part E **robustdetails**<sup>®</sup>, habitable rooms are all rooms except the hall, staircase and landing.

### **Internal wall**

A wall or partition which divides the dwelling space into different functions but which does not provide separation between different dwellings.

### **Internal floor**

A floor which divides the dwelling space into different functions but which does not provide separation between different dwellings.

### **$L'_{nT}$**

Standardised impact sound pressure level. The impact sound pressure level in the receiving room at a stated frequency, corrected (normalised) for the reverberation time in the receiving room. See BS EN ISO 140-7.

### **$L'_{nT,w}$**

Weighted standardised impact sound pressure level. A single-number quantity (weighted) to characterise the impact sound insulation of floors. See BS EN ISO 717-2.

### **Mass per unit area (or surface density)**

Mass per unit area is expressed in kilograms per square metre (kg/m<sup>2</sup>).

### **Mineral wool**

A rock or glass based mineral material which can be manufactured in a quilt form or batt (more rigid) form.

### **Nominal density of gypsum-based board**

The density stated in the Robust Detail with a tolerance of up to -0.3 kg/m<sup>2</sup> per layer.

### **Proprietary screed**

A self-compacting floor screed, which achieves a nominal mass per unit area of 80 kg/m<sup>2</sup> as laid, without the requirement for manual or mechanical compacting.

### **$rd\Delta L_w$**

This is specific to **robustdetails**<sup>®</sup> performance requirements and is the difference in weighting between two floor impact tests undertaken in an acoustic test laboratory. This should not be confused with the Approved Document E  $\Delta L_w$  using BS EN ISO 717-2.

### **$rd\Delta R_w+C_{tr}$**

This is specific to **robustdetails**<sup>®</sup> performance requirements and is the difference in weighting between two floor airborne tests undertaken in an acoustic test laboratory.

### **Rigid closer**

A rigid cavity stop or cavity barrier which seals the air path in cavities linking adjoining dwellings. This can be timber or other rigid board material.

### **Rip liner**

Small section of wall lining material or any board material fitted in advance of the main wall lining to allow the installation of the floating floor treatment. This does not necessarily need to be the same thickness as the wall lining material.

Particular attention should also be paid to Building Regulations Part B – Fire Safety.

### **Robust Detail**

A Robust Detail for Part E of the Building Regulations has been given the status of Robust Detail following a minimum of 30 “field tests” where the recorded mean performance was 5 dB better than the sound insulation requirements as described in Approved Document E for new build separating walls and floors.

### **$R_w$**

A single-number quantity (weighted) which characterises the airborne sound insulation of a building element from measurements undertaken in an acoustic test laboratory. See BS EN ISO 717-1.

### **Sealant (acoustic or flexible)**

A gun-applied sealant which has resilience and forms a non-rigid caulking.

### **Separating floor**

A floor that separates adjoining dwellings.

### **Separating wall**

A wall that separates adjoining dwellings.

### **Spandrel panel**

An element manufactured to divide or close off the profile in the roof space.

### **t&g**

Tongue and groove edged jointing of flooring boards (bonded lapped joints are also acceptable)