

September 2017 Update Pack

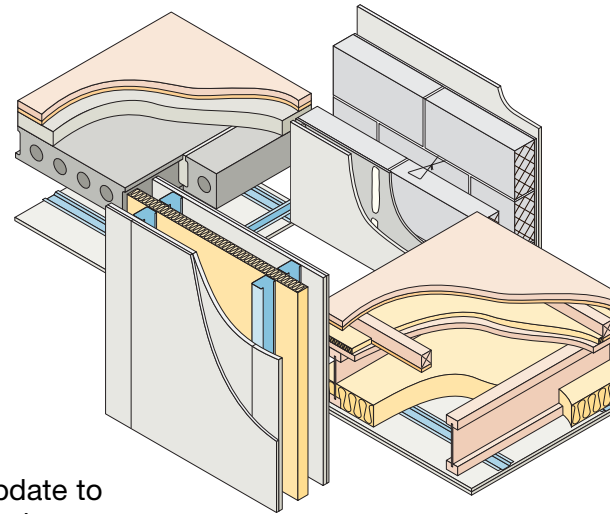

Dear Colleague,

2017 has been very busy for us, with this one being the **fifth** update to the Handbook in one year – the first time this has ever happened.

In this update pack, we are pleased to include a further new wall type, **E-WM-31**. Using the innovative storey-height ‘Celcon Elements’ from H+H, and thin-joint technology, this insulated cavity wall has been proven to consistently achieve performance 5 dB better than that required under Building Regulations Part E.

A new “room-in-roof” system has also been added to Appendix A2. The ‘Rapid Fit System’ from NYTimber is specifically for use on E-WM-17, allowing the 3-credit performance of that wall to be maintained.

Appendix A1 now has a generic solution for spandrels on timber frame walls alongside the one for masonry walls; and both can now use a single layer of Fermacell as an alternative to the 2 layers of 8 kg/m² gypsum-based board.

Other amendments include: Tekfloor Tekrubber resilient layer added to E-FC-15; and EPS added as an alternative inner leaf insulation to E-WT-2 and E-FT-1.

Please update your June 2017, 4th Edition Handbook as follows:

1. Remove and replace all pages of the Introduction.
2. Insert the new Robust Detail E-WM-31 to the end of the ‘Separating Walls, Masonry’ section.
3. Remove and replace just the first page (p.1 - p.2) of E-WT-2.
4. Remove and replace all pages of E-FC-15.
5. Remove and replace just the first page (p.1 - p.2) of E-FT-1.
6. Remove and replace all pages of Appendix A1.
7. Remove and replace all pages of Appendix A2.

Yours sincerely

A handwritten signature in black ink, appearing to read 'John Tebbit', written over a horizontal line.

John Tebbit

Chief Executive,
Robust Details Limited



Changes to the fourth edition following September 2017 update

Section Page Amendment

Introduction

Table 1	3	New wall type E-WM-31 added.
Table 4	8	New wall type E-WM-31 added.
Table 6a	9	NYTROOF RAPID FIT SYSTEM added. New wall type E-WM-31 added.
Table 6a	10	Lightweight external cladding systems added.

Separating Wall – Masonry

E-WM-31

All	1-6	New Robust Detail separating wall added – Celcon Elements aircrete panels (gypsum-based board) with minimum 100mm insulated cavity.
-----	-----	---

Separating Wall – Timber

E-WT-2

External (flanking) wall junctions	2	EPS added as an option for the inner leaf insulation.
------------------------------------	---	---

Separating Floor – Concrete

E-FC-15

All	1-6	Tekfloor TekRubber added as an alternative resilient layer system.
-----	-----	--

Separating Floor – Timber

E-FT-1

External (flanking) wall junction	2	EPS added as an option for the inner leaf insulation.
-----------------------------------	---	---

Appendix A1

Spandrel panels	5	1 layer of 15mm Fermacell added as an alternative lining. Generic single-leaf spandrel for use on timber frame walls added.
-----------------	---	--

Appendix A2

Contents	1	NYTROOF RAPID FIT SYSTEM added. Lightweight external cladding systems added.
NYTROOF RAPID FIT SYSTEM	10	New proprietary roofing system added.
Lightweight external cladding	11	New generic cladding system added.

This Handbook contains the separating wall and separating floor constructions that have achieved the status of Robust Details for Part E of the Building Regulations (England and Wales) and Part G of the Building Regulations (Northern Ireland), “Resistance to the passage of sound”.

The Robust Details have undergone an extensive sound insulation testing regime, robust design analysis and independent audit and have satisfied the Robust Details Limited Management Board that they should provide a level of sound insulation compliant with Part E (England and Wales) and Part G (Northern Ireland).

The use of the **robustdetails**[®] scheme provides an alternative to pre-completion testing for demonstrating compliance with the performance standards for new build dwellings. Every dwelling built using the **robustdetails**[®] scheme needs to be registered with Robust Details Limited and a plot registration fee paid. Further information on the scheme (including how to apply for new Robust Details) is available on the Robust Details Limited web site at:

www.robustdetails.com

or from:

Robust Details Limited
Block E
Bletchley Park Science and Innovation Centre
Milton Keynes
Buckinghamshire
MK3 6EB

Telephone: 03300 882140 - Technical
03300 882141 - General

Fax: 01908 363433

Each Robust Detail includes materials and construction details for the separating wall/floor and its key interfaces with other elements and should be read in conjunction with Appendix A. The final page of each Robust Detail is a checklist, which should be photocopied and used by the site manager/supervisor to confirm that the separating wall/floor has been built correctly. The building control body may ask to see the checklist.

It is important that separating walls/floors and their associated junctions and flanking conditions are constructed entirely in accordance with the relevant Robust Detail; otherwise the building control body may require pre-completion testing to be carried out.

The tables on pages 5, 6 and 7 show which **robustdetails**[®] separating floors and walls can be used in flats/apartments.

Note:

The contents of this Handbook relate only to compliance with specific aspects of Part E (England and Wales) and Part G (Northern Ireland). Building work will also have to comply with all other relevant legislation and Parts of the Building Regulations.

Where sound testing is required on a wall or floor, the user should seek expert acoustic advice prior to construction commencing.

Terms and Conditions:

Please refer to www.robustdetails.com for full terms and conditions.

®: UK registered trade mark no. 2291665

© Robust Details Limited 2011. All rights reserved. No part of this Handbook (other than the checklists) may be reproduced in any material form or issued or communicated to the public (including photocopying or storing it in any medium by electronic means, and whether or not transiently or incidentally to some other use of this Handbook) without the prior written permission of Robust Details Limited except in accordance with the provisions of the Copyright, Designs and Patents Act 1988.

Warning: the doing of an unauthorised act in relation to a copyright work may result in both a civil claim for damages and criminal prosecution.

Introduction

Special note for Robust Details constructed in Northern Ireland

Members of an expert panel convened to advise NI Government on the subject, consider that the following Robust Details will integrate most readily with NI standards and methods of construction.

Other Robust Details may be suitable for use in NI, however, it is recommended that Building Control be consulted to ensure full compatibility with other NI Regulations and Standards.

Masonry walls	E-WM-1	Concrete floors	E-FC-1	
	E-WM-2		E-FC-2	
	E-WM-3		E-FC-4	
	E-WM-4		E-FC-5	
	E-WM-11		E-FC-6	
	E-WM-16		E-FC-8	
	E-WM-18		E-FC-9	
	E-WM-19		E-FC-10	
	E-WM-21		E-FC-11	
	E-FC-12			
	E-FC-13			
	E-FC-14			
Timber walls	E-WT-1			
	E-WT-2			
	E-WT-4			
Timber floors	E-FT-1			
	E-FT-2			
	E-FT-3			
	E-FT-5			
	E-FT-6			
Steel floors	E-FS-1			

Note:

Refer to Tables 3a, 3b and 3c in the Introduction for valid combinations of the Robust Details walls and floors.

Introduction

List of Robust Details

Table 1 – Separating walls

E-WM-1	masonry – dense aggregate blockwork (wet plaster)
E-WM-2	masonry – lightweight aggregate blockwork (wet plaster)
E-WM-3	masonry – dense aggregate blockwork (render and gypsum-based board)
E-WM-4	masonry – lightweight aggregate blockwork (render and gypsum-based board)
E-WM-5	masonry – Besblock “Star Performer” cellular blockwork (render and gypsum-based board)
E-WM-6	masonry – aircrete blockwork (render and gypsum-based board)
E-WM-7	Suspended from further registrations
E-WM-8	masonry – lightweight aggregate blockwork Saint Gobain – Isover RD35 (gypsum-based board)
E-WM-9	masonry – solid dense aggregate blockwork (render and gypsum-based board)
E-WM-10	masonry – aircrete thin joint blockwork with specified wall ties (render and gypsum-based board finish)
E-WM-11	masonry – lightweight aggregate blockwork (render and gypsum-based board) with 100mm minimum cavity
E-WM-12	masonry – Plasmor “Aglite Ultima” lightweight aggregate blockwork (render and gypsum-based board)
E-WM-13	masonry – aircrete thin joint - untied blockwork (render and gypsum-based board)
E-WM-14	masonry – lightweight aggregate blockwork Saint Gobain – Isover RD35 (gypsum-based board) with 100mm minimum cavity
E-WM-15	masonry – aircrete blockwork Saint Gobain - Isover RD35 (gypsum-based board)
E-WM-16	masonry – dense aggregate blockwork (render and gypsum-based board) with 100mm minimum cavity
E-WM-17	masonry – lightweight aggregate blockwork Saint Gobain-Isover RD Party Wall Roll (gypsum-based board)
E-WM-18	masonry – dense aggregate blockwork (wet plaster) with 100mm minimum cavity
E-WM-19	masonry – dense or lightweight aggregate blockwork (render and gypsum-based board) with 100mm minimum cavity and MONARFLOOR® BRIDGESTOP® system
E-WM-20	masonry – lightweight aggregate blockwork Saint Gobain – Isover RD Party Wall Roll (gypsum-based board) with 100mm minimum cavity
E-WM-21	masonry – lightweight aggregate blockwork (wet plaster) with 100mm minimum cavity
E-WM-22	masonry – lightweight aggregate blockwork – Knauf Earthwool Masonry Party Wall Slab or Superglass Party Wall Roll or URSA Cavity Batt 35 or URSA PARTY WALL ROLL (gypsum-based board) with 100mm minimum cavity
E-WM-23	masonry – aircrete blockwork Superglass Party Wall Roll (gypsum-based board) with 100mm minimum cavity
E-WM-24	masonry – aircrete blockwork Saint Gobain – Isover RD Party Wall Roll (gypsum-based board) with 100mm minimum cavity
E-WM-25	masonry – Porotherm clay blockwork (Ecoparge and gypsum-based board) with 100mm minimum insulated cavity
E-WM-26	masonry – Besblock “Star Performer” cellular blockwork (gypsum-based board) with 100mm minimum insulated cavity
E-WM-27	masonry – lightweight aggregate blockwork Superglass Party Wall Roll (gypsum-based board) with minimum 75mm cavity
E-WM-28	masonry – lightweight aggregate blockwork Knauf Party Wall Wool (gypsum-based board) with minimum 100mm cavity
E-WM-29	masonry – Porotherm clay blockwork (Ecoparge and gypsum-based board) with 75mm minimum insulated cavity
E-WM-30	masonry – aircrete blockwork Knauf Party Wall Wool (gypsum-based board) with 100mm minimum cavity
E-WM-31	masonry – H+H – Celcon Elements (gypsum-based board) with 100mm minimum insulated cavity

See over for timber and steel frame walls

Introduction

List of Robust Details

Table 1 (continued) – Separating walls

E-WT-1	timber frame – without sheathing board
E-WT-2	timber frame – with sheathing board
E-WT-3	timber frame – Elecoframe prefabricated panels
E-WT-4	timber frame – Excel Industries Warmcell 500 insulation - with sheathing board
E-WS-1	steel frame – twin metal frame
E-WS-2	steel frame – British Gypsum Gypwall QUIET IWL
E-WS-3	steel frame – modular steel frame housing
E-WS-4	steel frame – twin metal frame - 250mm between linings
E-WS-5	steel frame – twin metal frame

Introduction

List of Robust Details

Table 2 – Separating floors

E-FC-1	precast concrete plank with directly applied screed and floating floor treatment
E-FC-2	in-situ concrete slab and floating floor treatment
E-FC-3	Suspended from further registrations
E-FC-4	precast concrete plank and Thermal Economics IsoRubber system and floating screed
E-FC-5	precast concrete plank and Cellecta Yelofon HD10+ system and floating screed
E-FC-6	beam and block with concrete topping Regupol E48 system and floating screed
E-FC-7	beam and block with concrete topping and floating floor treatment
E-FC-8	precast concrete plank with floating screed and bonded resilient floor covering
E-FC-9	precast concrete plank with directly applied screed and Thermal Economics IsoRubber top bonded resilient floor covering
E-FC-10	in-situ concrete slab with Thermal Economics IsoRubber top bonded resilient floor covering
E-FC-11	precast concrete plank and Icopal-MONARFLOOR® Tranquilt and floating screed
E-FC-12	precast concrete plank and Thermal Economics IsoRubber Base HP3 system and floating screed
E-FC-13	precast concrete plank and InstaCoustic InstaLay 65 system and floating screed
E-FC-14	precast concrete plank and Thermal Economics IsoRubber Code layer and floating screed
E-FC-15	precast concrete plank and Regupol Quietlay layer and floating screed
E-FC-16	precast concrete plank with directly applied screed and Thermal Economics IsoRubber CC3 bonded resilient floor covering
E-FC-17	precast concrete plank and Cellecta YELOfon® HD10+ system and floating screed and Cellecta ULTRA ceiling treatment
E-FC-18	in-situ concrete slab with floating screed or bonded resilient floor covering
E-FT-1	timber I-joists and floating floor treatment
E-FT-2	timber solid joists and floating floor treatment
E-FT-3	MiTek Posi-Joist, Prestoplan PresWeb, WOLF easi-joist, ITW Gang-Nail Ecojoist or ITW Alpine SpaceJoist metal web timber joist and floating floor treatment
E-FT-4	timber Finnjoists with Finnforest Acoustic layer and Gyvlon screed
E-FT-5	Cellecta ScreedBoard® 28 system on timber I-joists
E-FT-6	Cellecta ScreedBoard® 28 system on metal web joists
E-FT-7	timber I-joists and FFT80 floating floor treatment
E-FT-8	timber solid joists and FFT80 floating floor treatment
E-FS-1	steel deck and in-situ concrete and floating floor treatment
E-FS-2	UltraBEAM metal joists and floating floor treatment
E-FS-3	Cellecta ScreedBoard® 28 system on metal joists

Introduction

Table 3a – Combinations of Robust Details separating walls and floors for flats/apartments in **loadbearing masonry** constructions

Separating walls		Separating floors					
		E-FC-1 E-FC-11 E-FC-12 E-FC-13	E-FC-14 E-FC-15 E-FC-16 E-FC-17	E-FC-4	E-FC-5	E-FC-6 E-FC-7	E-FC-8 E-FC-9 E-FC-10
E-WM-1	E-WM-16	✓		✓	✓	✓	✓
E-WM-3	E-WM-18						
E-WM-2	E-WM-20						
E-WM-4	E-WM-21						
E-WM-5	E-WM-26	✓		✓	✓	F	✓
E-WM-8	E-WM-27						
E-WM-11	E-WM-28						
E-WM-14							
E-WM-6	E-WM-23						
E-WM-10	E-WM-24	F		✓	✓ see note 1	F	✓
E-WM-13	E-WM-30						
E-WM-15							
E-WM-12		F		✓	F	F	F
E-WM-17	E-WM-22	✓ see note 2		✓	✓ see note 2	F	✓ see note 2
E-WM-25	E-WM-29	F		F	F	F	F

Key

F Only the separating floor requires pre-completion sound testing.

1 Where this combination is selected, 200mm (min) thick precast concrete planks and ceiling treatment CT5 must be used.

2 This combination can only be selected where the construction does not include Plasmor Aglite Ultima blocks (1050 kg/m³).

Combining robustdetails® loadbearing masonry walls and floors with robustdetails® lightweight framed separating walls

Upper storeys of blocks of flats may be constructed using lightweight steel or timber frame, where the lower storeys are loadbearing masonry.

The lightweight separating walls built directly off the uppermost concrete separating floors may be registered as Robust Details provided:

- the lightweight walls are in vertical alignment with the masonry walls below, such that they can follow the principles of the ground floor junction shown for the relevant robustdetails® separating wall;
- the external (flanking) wall construction above the separating floor meets the requirements on page 2 of the relevant robustdetails® separating wall, and has 2 layers of gypsum-based board;
- the junction between the bottom rail (or sole plate) is well sealed;
- all other relevant requirements in the Handbook are strictly followed.

The separating floor may be registered as a Robust Detail provided:

- the floor is constructed in accordance with the requirements of the published Detail;
- the external (flanking) wall below the precast concrete floor satisfies the requirements of detail 1 on page 2 of the relevant robustdetails® separating floor;
- all other relevant requirements in the Handbook are strictly followed.

Introduction

Table 3b – Combinations of Robust Details separating walls and floors for flats/apartments in timber frame constructions

Separating walls	Separating floors	
	E-FT-1 E-FT-2 E-FT-3 E-FT-4 E-FT-5 E-FT-6 E-FT-7 E-FT-8	E-FC-2 E-FC-18 E-FS-1
E-WT-1	✓	W see note 1
E-WT-2	✓	W see note 1
E-WT-3	F	W see note 1
E-WT-4	F	W see note 1

Table 3c – Combinations of Robust Details separating walls and floors for flats/apartments in reinforced concrete and steel frame constructions

Separating walls	Separating floors					
	E-FC-2	E-FC-10	E-FC-18	E-FS-1	E-FS-2	E-FS-3
E-WS-1	W see note 1	W	W see note 1	W see note 1	✓	✓
E-WS-2	✓	W	✓ see note 2	W	W	W
E-WS-3	W	W	W	W	W	W
E-WS-4	W see note 1	W	W see note 1	W see note 1	✓	✓
E-WS-5	✓	✓	✓	W	W	W

Key for Table 3b and Table 3c

F Only the separating floor requires pre-completion sound testing.

W Only the separating wall requires pre-completion sound testing.

1 Lightweight steel and timber frame walls may be constructed above in-situ poured concrete floors.

The lightweight walls built directly off the concrete floors may be registered as Robust Details provided:

- they meet all other requirements of the Robust Detail, including flanking constructions;
- the principles of the raft foundation junction are followed. As such, the concrete of the floor must have a mass of 365 kg/m² (min), and a floating floor treatment must be provided to shield the base of the wall, as shown in the Separating Wall junction in the floor Robust Detail;
- Walls constructed to the soffit of in-situ poured concrete floors cannot be registered as Robust Details and may be subject to pre-completion sound testing.

2 A floating screed must be installed up to the separating wall as shown in the separating floor detail.

See also notes relating to [Combining loadbearing masonry and lightweight framed separating walls](#) included under Table 3a.

Introduction

Table 4 – Combining Robust Details separating walls with non-Robust Details separating floors in flats/apartments

Loadbearing masonry			
E-WM-1	F1	E-WM-21	F1
E-WM-2	F1	E-WM-22	F1
E-WM-3	F1	E-WM-23	F1
E-WM-4	F1	E-WM-24	F1
E-WM-5	F1	E-WM-25	F1
E-WM-6	F1	E-WM-26	F1
E-WM-8	F1	E-WM-27	F1
E-WM-10	F1	E-WM-28	F1
E-WM-11	F1	E-WM-29	F1
E-WM-12	F1	E-WM-30	F1
E-WM-13	F1	E-WM-31	F1
E-WM-14	F1		
E-WM-15	F1		
E-WM-16	F1		
E-WM-17	F1		
E-WM-18	F1		
E-WM-20	F1		

Timber frame		Light steel frame	
E-WT-1	F2	E-WS-1	F3
E-WT-2	F2	E-WS-2	F4
E-WT-3	F2	E-WS-3	F3
E-WT-4	F2	E-WS-4	F3
		E-WS-5	F4

- Key**
- F1** Only the separating floor requires pre-completion testing provided the floor does not bridge the separating wall cavity. Otherwise both the wall and floor need testing.
 - F2** Only the separating floor requires pre-completion testing provided the floor is timber-based and does not bridge the separating wall cavity. Otherwise both the wall and floor need testing.
 - F3** Only the separating floor requires pre-completion testing provided the wall is being used in a lightweight steel frame flat/apartment and the floor does not bridge the separating wall cavity. Otherwise both the wall and floor need testing.
 - F4** Only the separating floor requires pre-completion testing provided the wall is being used in a concrete frame building and the floor has the required floor treatment (see notes under Table 3c). Otherwise both the wall and floor need testing.

Table 5 – Combining Robust Details separating floors with non-Robust Details separating walls in flats/apartments

Loadbearing masonry			
E-FC-1	W1	E-FC-11	W1
E-FC-4	W2	E-FC-12	W1
E-FC-5	W2	E-FC-13	W1
E-FC-6	W1	E-FC-14	W1
E-FC-7	W1	E-FC-15	W1
E-FC-8	W2	E-FC-16	W1
E-FC-9	W2	E-FC-17	W1
E-FC-10	W2		

Timber frame		RC frame	
E-FT-1	W3	E-FC-2	W4
E-FT-2	W3	E-FC-10	W4
E-FT-3	W3	E-FC-18	W4
E-FT-4	W3		
E-FT-5	W3		
E-FT-6	W3		
E-FT-7	W3		
E-FT-8	W3		

Light steel frame			
		E-FS-1	W4
		E-FS-2	W5
		E-FS-3	W5

- Key**
- W1** Only the separating wall requires pre-completion testing provided the wall is constructed using aggregate blocks specified for the inner leaf in the floor Robust Detail. Otherwise both the floor and wall need testing.
 - W2** Only the separating wall requires pre-completion testing provided the wall is constructed using blocks specified for the inner leaf in the floor Robust Detail. Otherwise both the floor and wall need testing.
 - W3** Only the separating wall requires pre-completion testing if used with timber frame supporting walls and twin leaf timber frame separating walls. Otherwise both the floor and wall need testing.
 - W4** Only the separating wall requires pre-completion testing provided the external wall meets the specification given in the separating floor Robust Detail. Otherwise both the floor and wall need testing.
 - W5** Only the separating wall requires pre-completion testing if used with steel frame supporting walls and twin leaf steel frame separating walls. Otherwise both the floor and wall need testing.

For any construction that requires a separating element to be tested, the user should seek expert acoustic advice on the design and potential acoustic performance.

Introduction

Table 6a – Robust Detail separating walls which can be used together with the proprietary flanking constructions contained in Appendix A2

		BRIDGESTOP® system	Smartroof system	Wall Cap RDA2	RoofSpace I-Roof	Space4 system	Stewart Milne Sigma® Panel	NYTROOF RAPID FIT SYSTEM
Masonry walls	E-WM-1	✓		✓				
	E-WM-2	✓		✓				
	E-WM-3	✓	✓	✓	✓			
	E-WM-4	✓	✓	✓	✓			
	E-WM-5	✓	✓	✓	✓			
	E-WM-6		✓	✓	✓			
	E-WM-8	✓	✓	✓	✓			
	E-WM-9							
	E-WM-10		✓	✓	✓			
	E-WM-11	✓	✓	✓	✓			
	E-WM-12	✓	✓	✓	✓			
	E-WM-13		✓	✓	✓			
	E-WM-14	✓	✓	✓	✓			
	E-WM-15		✓	✓	✓			
	E-WM-16	✓	✓	✓	✓			
	E-WM-17	✓	✓	✓	✓	✓		✓
	E-WM-18	✓		✓				
	E-WM-19	✓ see note 1						
	E-WM-20	✓	✓	✓	✓			
	E-WM-21	✓		✓				
	E-WM-22	✓	✓	✓	✓			
	E-WM-23	✓ see note 1	✓	✓	✓			
	E-WM-24	✓ see note 1	✓	✓	✓			
	E-WM-25			✓				
	E-WM-26	✓	✓	✓	✓	✓		
	E-WM-27	✓	✓	✓	✓			
	E-WM-28	✓	✓	✓	✓			
	E-WM-29			✓				
	E-WM-30	✓ see note 1	✓	✓	✓			
	E-WM-31		✓	✓	✓			

Key

1 When constructing these walls off raft foundations, the raft must have insitu concrete with 150mm minimum thickness.

See over for timber and steel frame walls

Introduction

Table 6a (continued) – Robust Detail separating walls which can be used together with the proprietary flanking constructions contained in Appendix A2

		Smartroof system	Kingspan TEK	Prestoplan PresPeak 60	Wall Cap RDA2	RoofSpace I-Roof	Space4 system	Stewart Milne Sigma® Panel	Lightweight external cladding systems
Timber walls	E-WT-1	✓	✓	✓	✓	✓		✓	✓
	E-WT-2	✓	✓	✓	✓	✓	✓	✓	✓
	E-WT-3	✓			✓	✓			
	E-WT-4	✓			✓	✓			
Steel walls	E-WS-1					✓			
	E-WS-2								
	E-WS-3								
	E-WS-4				✓				
	E-WS-5								

Introduction

Table 6b – Robust Detail separating floors which can be used together with the proprietary flanking constructions contained in Appendix A2

		BRIDGESTOP® system	Smartroof system	Kingspan TEK	Prestoplan PresPeak 60	Wall Cap RDA2	RoofSpace I-Roof	Space4 system	
Concrete floors	E-FC-1					✓			
	E-FC-2								
	E-FC-4					✓			
	E-FC-5					✓			
	E-FC-6					✓			
	E-FC-7					✓			
	E-FC-8					✓			
	E-FC-9					✓			
	E-FC-10					✓ see note 1			
	E-FC-11					✓			
	E-FC-12					✓			
	E-FC-13					✓			
	E-FC-14					✓			
	E-FC-15					✓			
	E-FC-16					✓			
	E-FC-17					✓			
	E-FC-18								
	Timber floors	E-FT-1					✓		
E-FT-2						✓			
E-FT-3						✓			
E-FT-4						✓			
E-FT-5						✓			
E-FT-6						✓			
E-FT-7						✓			
E-FT-8						✓			
Steel-concrete and steel floors	E-FS-1								
	E-FS-2					✓			
	E-FS-3					✓			

Key

1 Applies only to loadbearing masonry constructions.

Introduction

Table 7 – Robust Detail separating floors which can be used together with alternative products contained in Appendix A3

		British Gypsum GypFloor	Insumate insulation tray
Concrete floors	E-FC-1	✓	
	E-FC-2	✓	
	E-FC-4		
	E-FC-5		
	E-FC-6		
	E-FC-7	✓	
	E-FC-8		
	E-FC-9		
	E-FC-10		
	E-FC-11		
	E-FC-12		
	E-FC-13		
	E-FC-14		
	E-FC-15		
	E-FC-16		
	E-FC-17		
	E-FC-18		
	Timber floors	E-FT-1	
E-FT-2			✓
E-FT-3			✓
E-FT-4			
E-FT-5			
E-FT-6			
E-FT-7			✓
E-FT-8			✓
Steel-concrete and steel floors	E-FS-1	✓	
	E-FS-2		
	E-FS-3		

- Attached houses only ■
- H+H - Celcon Elements - thin joint ■
- Gypsum-based board (nominal 8 kg/m²) on dabs ■
- Used with 'SIG I-House System' ■

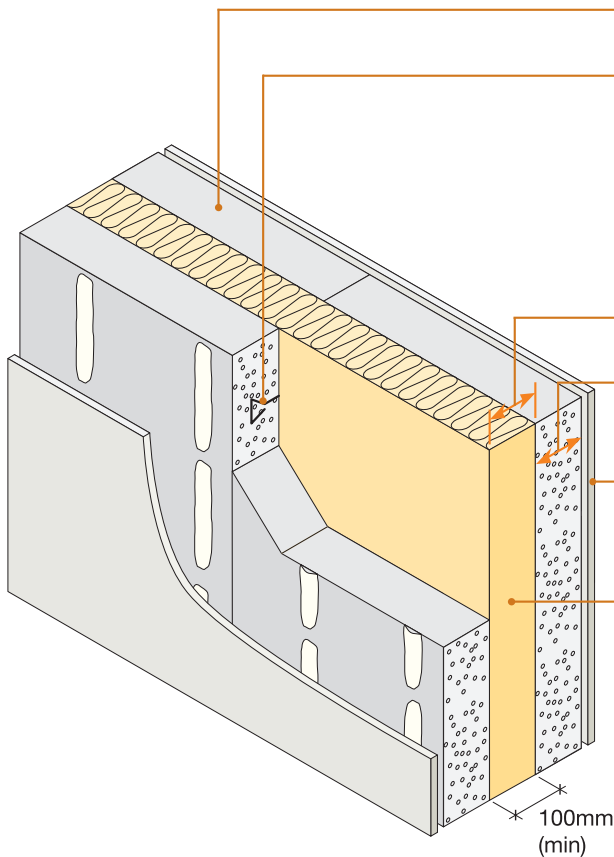

Element density	575 kg/m ³
Wall ties	Wall ties must be Vista VE4, Ancon Building Products Staifix HRT4 or Clan PWT4 installed at no more than 2 ties per storey height (see section 3)
Cavity width	100mm (min)
Element thickness	100mm (min), each leaf
Wall finish	Gypsum-based board (nominal 8 kg/m ²) mounted on dabs
Insulation	100mm mineral wool maximum density 40 kg/m ³
External (flanking) wall	Celcon Elements or aircrete 450-800 kg/m ³ 50mm (min) cavity – clear, fully filled or partially filled with insulation – and masonry outer leaf

DO

- Keep cavity, insulation and wall ties free from debris
- Fully fill all joints
- Make sure there is no connection between the two leaves except for wall ties, insulation and foundation
- Ensure all insulation sections are tightly butted together and half cuts are made with a clean sharp knife and are installed in accordance with the manufacturer's instructions
- Keep any chases for services to a minimum and fill well with mortar. Stagger chases on each side of the wall to avoid them being back to back
- Refer to Appendix A

1. External (flanking) wall junction

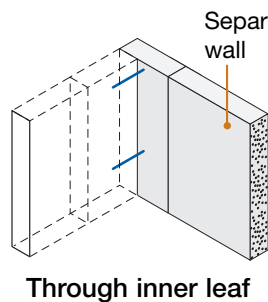
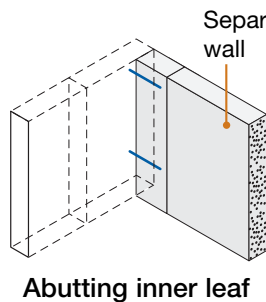
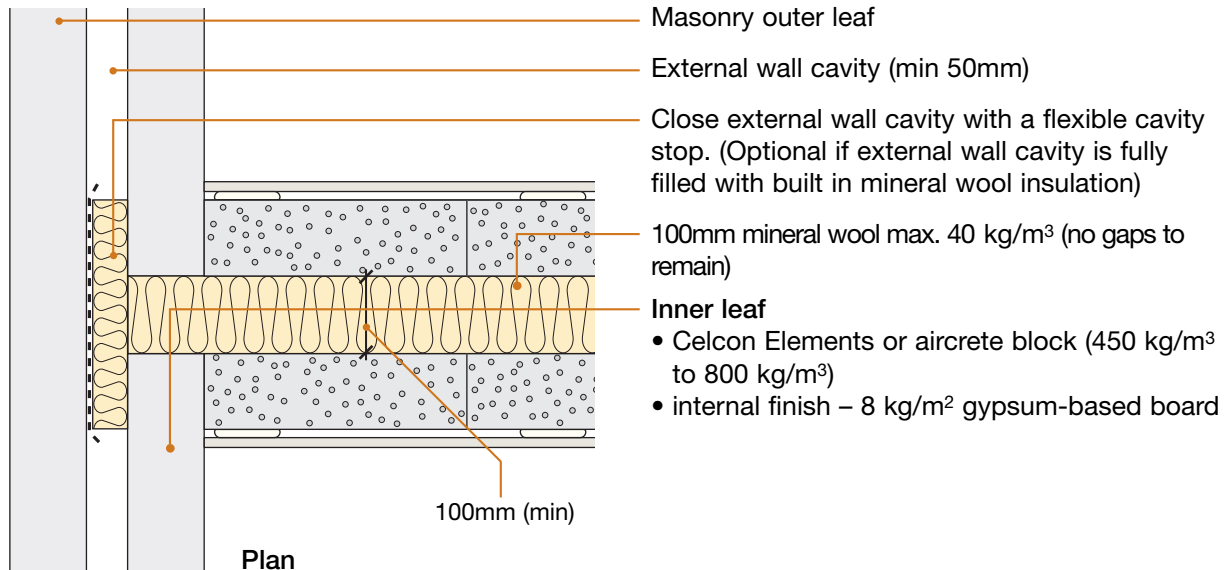

Separating wall Elements may abutt, or be taken through to the cavity face of the inner leaf

2. Staggered external (flanking) wall junction

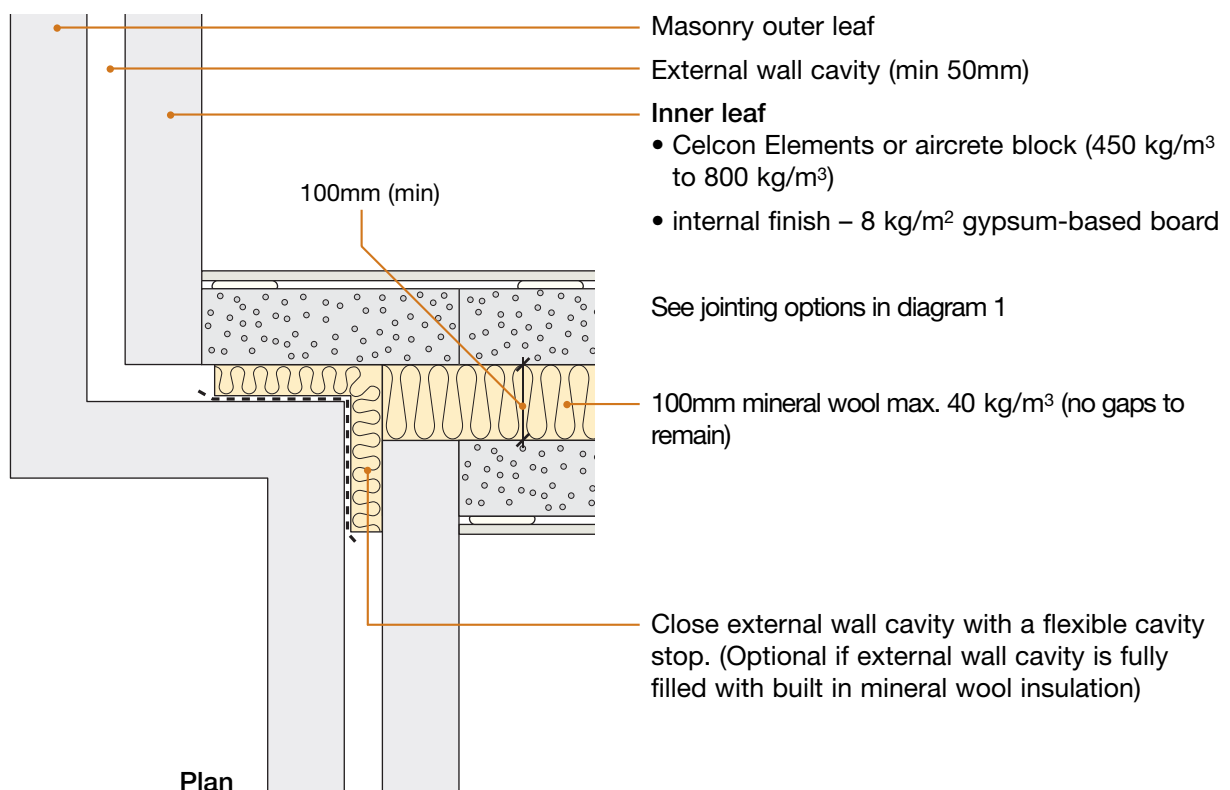

3. Wall tie placement

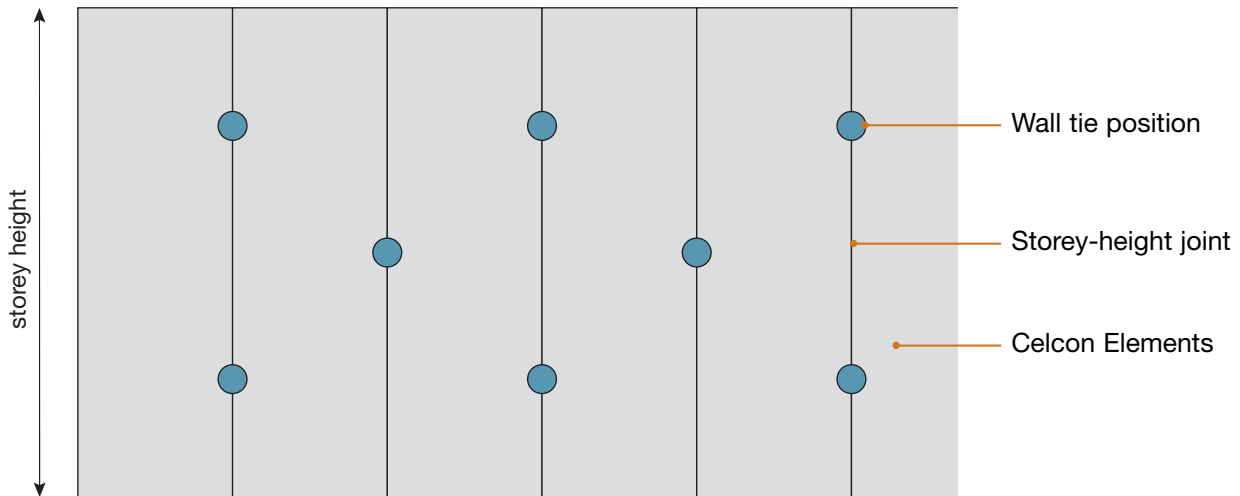

Only the following wall ties are permitted:

- Vista VE4
- Ancon Building Products Staifix HRT4
- Clan PWT4

Wall ties to be positioned following the alternating pattern shown above.

No more than 2 ties per storey-height joint

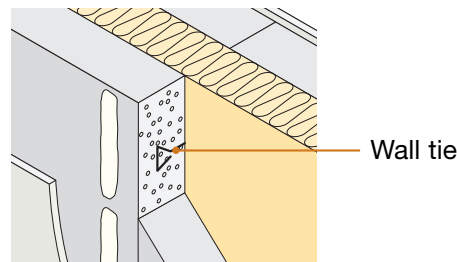

4. Internal floor junction: timber floor joists built in

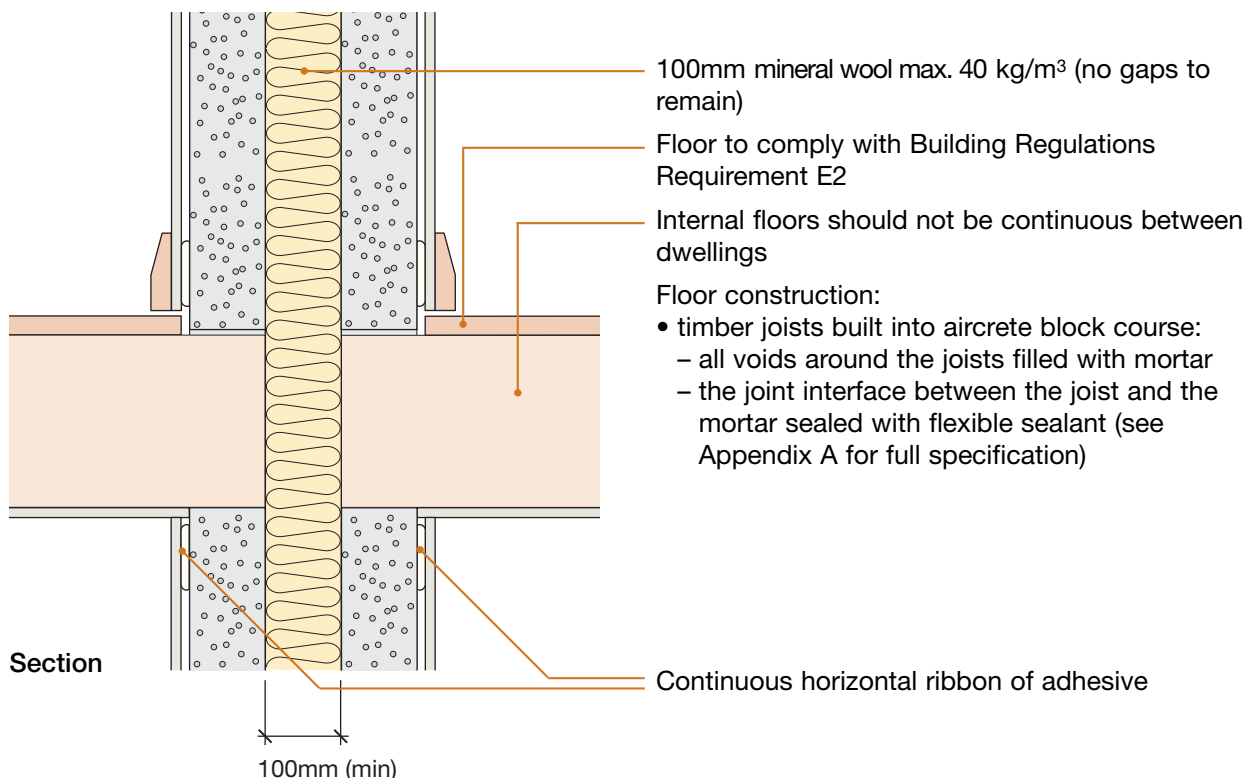

5. Ground floor junction: beam and block or precast concrete plank

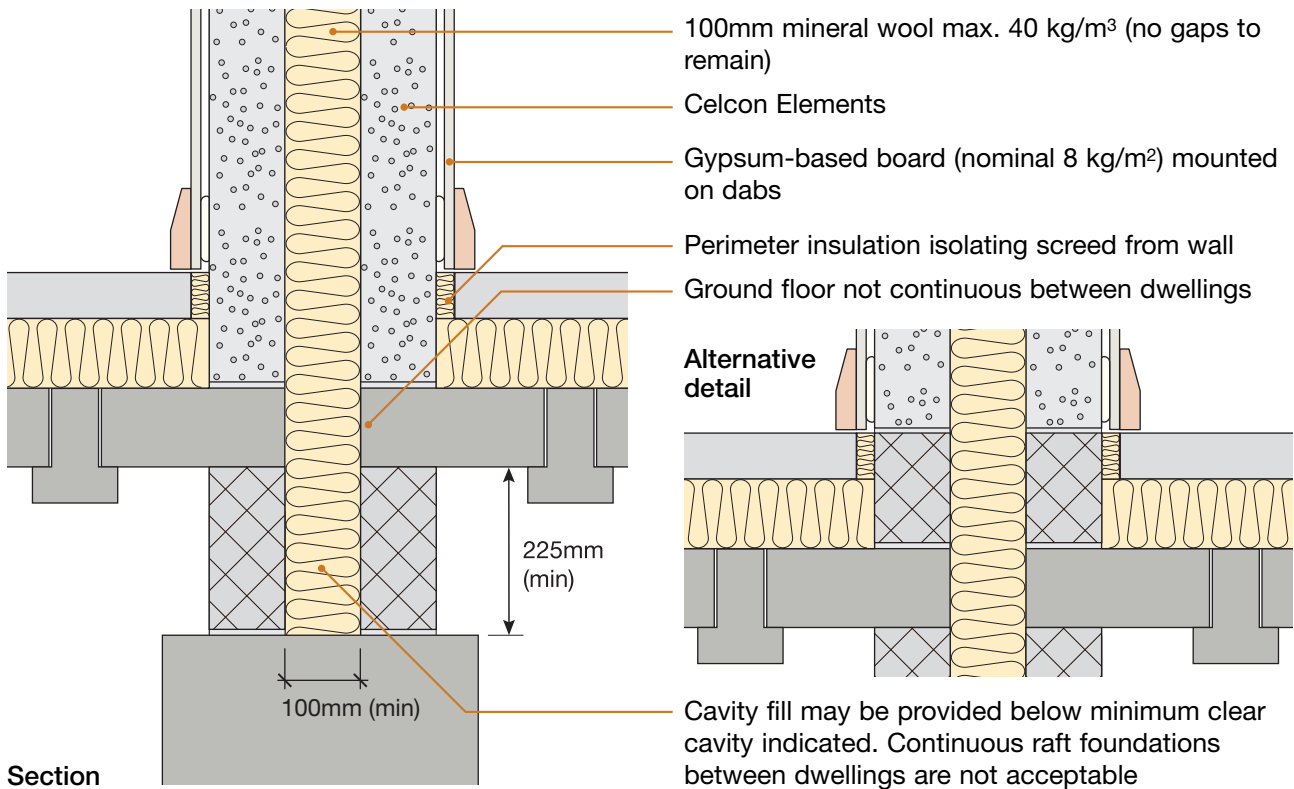

6. Ground floor junction: cast in-situ suspended concrete slab or ground bearing concrete slab

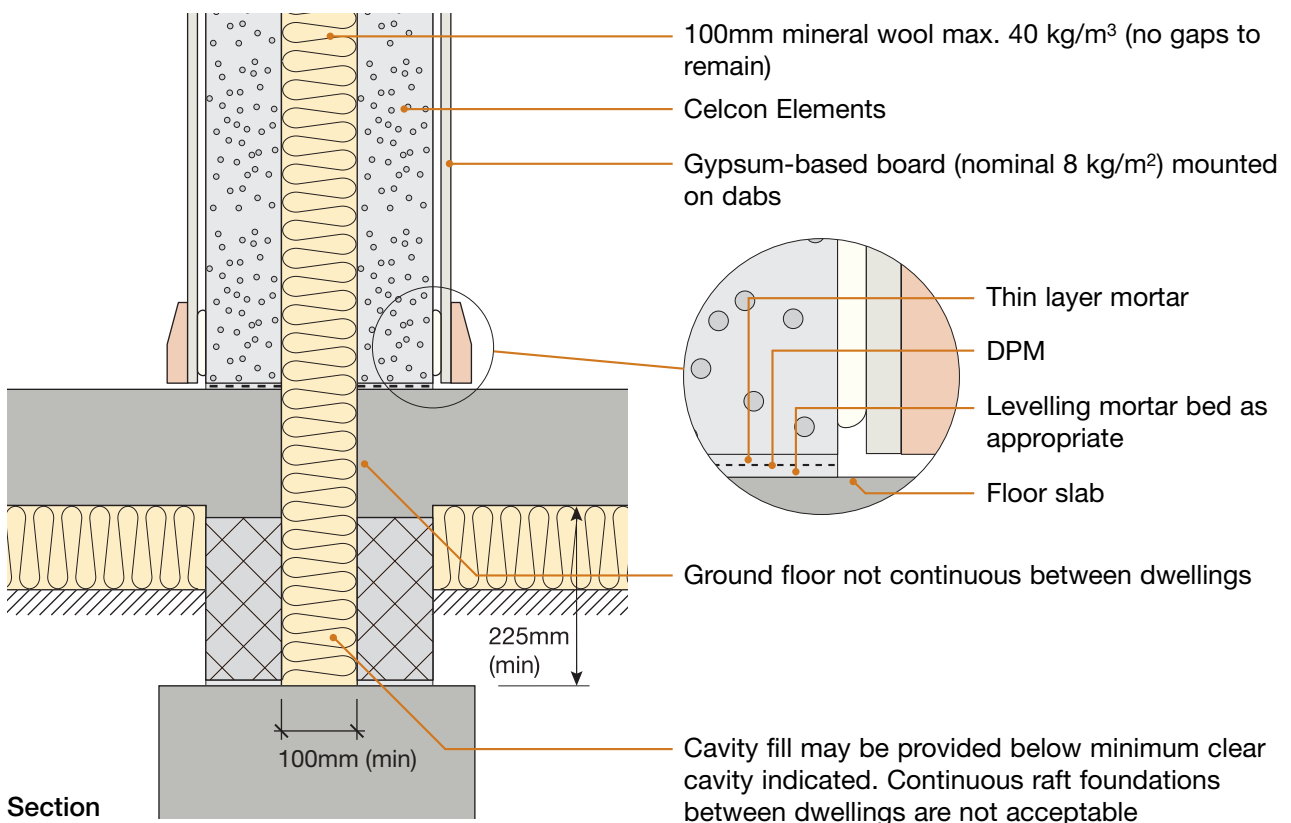

7. Roof junction – pitched roof without room-in-roof

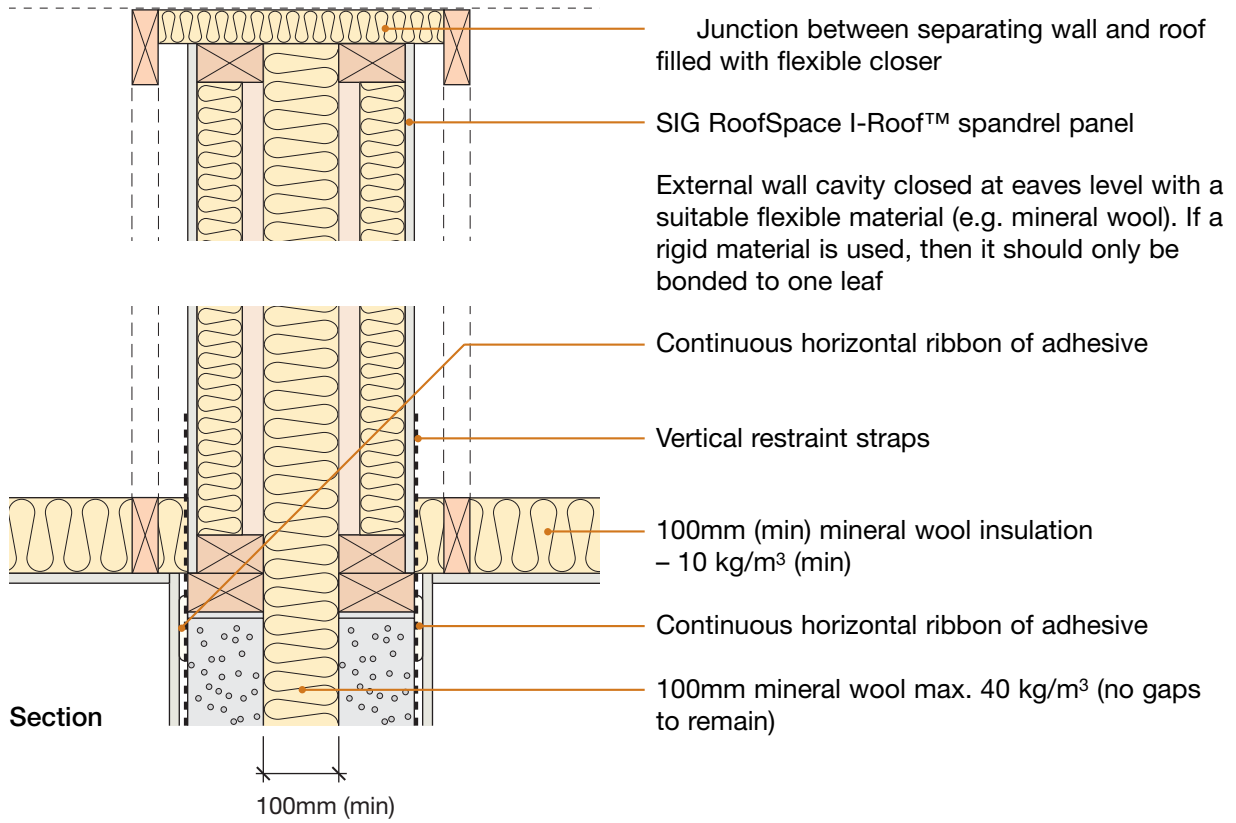

CHECKLIST (to be completed by site manager/supervisor)

Company: _____

Site: _____

Plot: _____ Site manager/supervisor: _____

Ref.	Item	Yes (✓)	No (✓)	Inspected (initials & date)
1.	Is separating wall cavity at least 100mm?	<input type="checkbox"/>	<input type="checkbox"/>	<input type="text"/>
2.	Is external (flanking) wall cavity at least 50mm?	<input type="checkbox"/>	<input type="checkbox"/>	<input type="text"/>
3.	Is external (flanking) wall inner leaf constructed from Celcon Elements or aircrete (450 to 800 kg/m ³)?	<input type="checkbox"/>	<input type="checkbox"/>	<input type="text"/>
4.	Are separating wall leafs constructed from Celcon Elements or aircrete (600 to 800 kg/m ³)?	<input type="checkbox"/>	<input type="checkbox"/>	<input type="text"/>
5.	Is cavity free from droppings and debris?	<input type="checkbox"/>	<input type="checkbox"/>	<input type="text"/>
6.	Are separating wall ties Vista VE4, Ancon Staifix HRT4 or Clan PWT4 installed at no more than 2 ties per storey-height joint?	<input type="checkbox"/>	<input type="checkbox"/>	<input type="text"/>
7.	Are cavity stops installed where specified in the Robust Detail?	<input type="checkbox"/>	<input type="checkbox"/>	<input type="text"/>
8.	Are joints fully filled?	<input type="checkbox"/>	<input type="checkbox"/>	<input type="text"/>
9.	Is 100mm mineral wool max. 40 kg/m ³ used, with no gaps remaining?	<input type="checkbox"/>	<input type="checkbox"/>	<input type="text"/>
10.	Is spandrel wall plate fully bedded on mortar, with no air gaps?	<input type="checkbox"/>	<input type="checkbox"/>	<input type="text"/>
11.	Are voids around floor joists, chases, etc. fully filled/sealed?	<input type="checkbox"/>	<input type="checkbox"/>	<input type="text"/>
12.	Where the ground floor has a floating floor treatment, has the perimeter insulation been installed?	<input type="checkbox"/>	<input type="checkbox"/>	<input type="text"/>
13.	Are all junctions of wall and ceiling boards sealed with tape or caulked with sealant?	<input type="checkbox"/>	<input type="checkbox"/>	<input type="text"/>
14.	Is separating wall satisfactorily complete?	<input type="checkbox"/>	<input type="checkbox"/>	<input type="text"/>

Contact details for technical assistance from:
Telephone: 01732 880580 Fax: 01732 887013 E-mail: technical@hcelcon.co.uk

Notes (include details of any corrective action)

Site manager/supervisor signature

©: UK registered trade mark no. 2291665
 © Robust Details Limited 2011. All rights reserved. No part of this Handbook (other than the checklists) may be reproduced in any material form or issued or communicated to the public (including photocopying or storing it in any medium by electronic means, and whether or not transiently or incidentally to some other use of this Handbook) without the prior written permission of Robust Details Limited except in accordance with the provisions of the Copyright, Designs and Patents Act 1988.
 Warning: the doing of an unauthorised act in relation to a copyright work may result in both a civil claim for damages and criminal prosecution.

- With sheathing board ■
- Twin timber frames ■

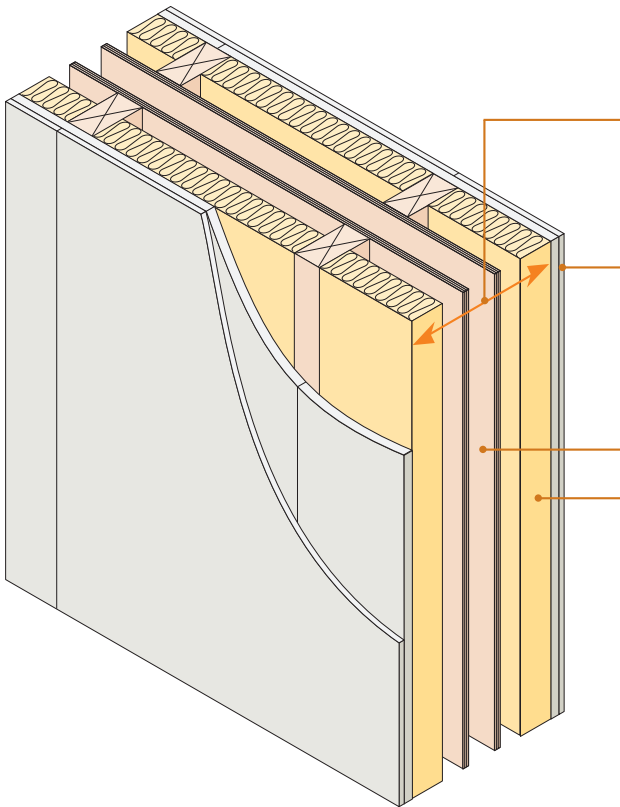

Wall width	240mm (min) between inner faces of wall linings. 50mm (min) gap between wall panels
Wall lining	- 2 or more layers of gypsum-based board (total nominal mass per unit area 22 kg/m ²), both sides - all joints staggered
Sheathing	9mm (min) thick board
Absorbent material	60mm (min) mineral wool batts or quilt (density 10 – 60 kg/m ³) both sides. Material may be unfaced, paper faced or wire-reinforced
Ties	Ties between frames not more than 40mm x 3mm, at 1200mm (min) centres horizontally, one row of ties per storey height vertically
External (flanking) wall	Outer leaf masonry with minimum 50mm cavity

Note: This specification is intended for use where the extent of sheathing required to the cavity face of the separating wall is greater than that permitted for E-WT-1

Structural framing details may vary slightly between different manufacturers and this is permitted, however, all dimension specifications within this Robust Detail must be adhered to.

Separating wall cavity insulation (optional)

The cavity may be insulated with mineral wool rolls or batts with a density of 18 – 40 kg/m³. Ensure insulation thickness is no greater than 10mm wider than cavity width to avoid excessive compression of the insulation.

- DO**
- Keep wall linings at least 240mm apart
 - Ensure that the 50mm (min) gap between the wall panels is maintained
 - Ensure quilt or batts cover whole lining area, fitting tight between studs without sagging
 - Ensure that all cavity stops/closers are flexible or are fixed to one frame only
 - Make sure there is no connection between the two leaves except where ties are necessary for structural reasons (see above)
 - Stagger joints in wall linings to avoid air paths
 - Seal all joints in outer layer with tape or caulk with sealant
 - Refer to Appendix A

1. External (flanking) wall junction

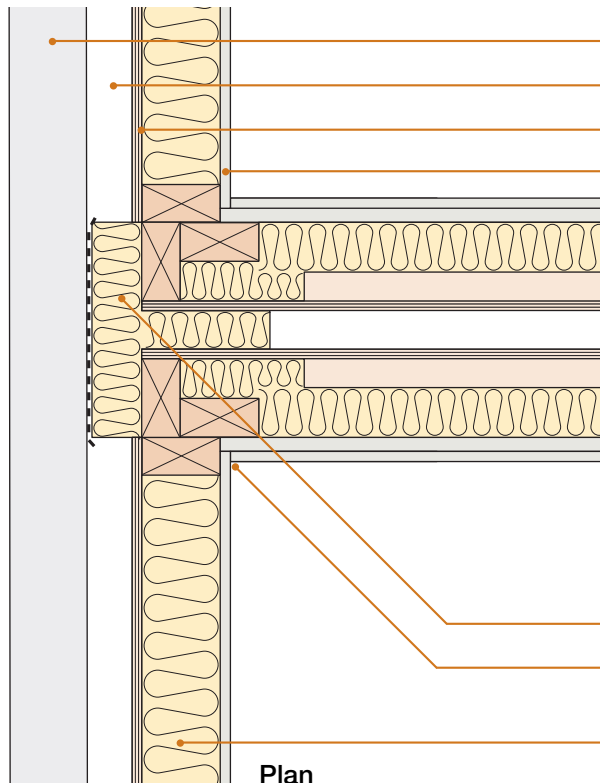

- Masonry outer leaf (min 100mm thick)
- External wall cavity (min 50mm)
- Sheathing board
- Inner leaf where there is no separating floor e.g. for houses
 - one layer of gypsum-based board nominal 8 kg/m²
- Inner leaf where there is a separating floor, e.g. for flats/apartments
 - if using **robustdetails**[®] for floor, refer to Table 3b in introduction to select an acceptable **robustdetails**[®] separating floor and use two layers of gypsum-based board nominal 8kg/m² each layer
 - if using floor requiring pre-completion testing, seek specialist advice
- Close cavity with a cavity stop (see Appendix A)
- Seal all perimeter joints with tape or caulk with sealant
- Mineral wool insulation 10 kg/m³ (min); 70mm (min) EPS or foil faced PIR with no gaps

2. Staggered external (flanking) wall junction

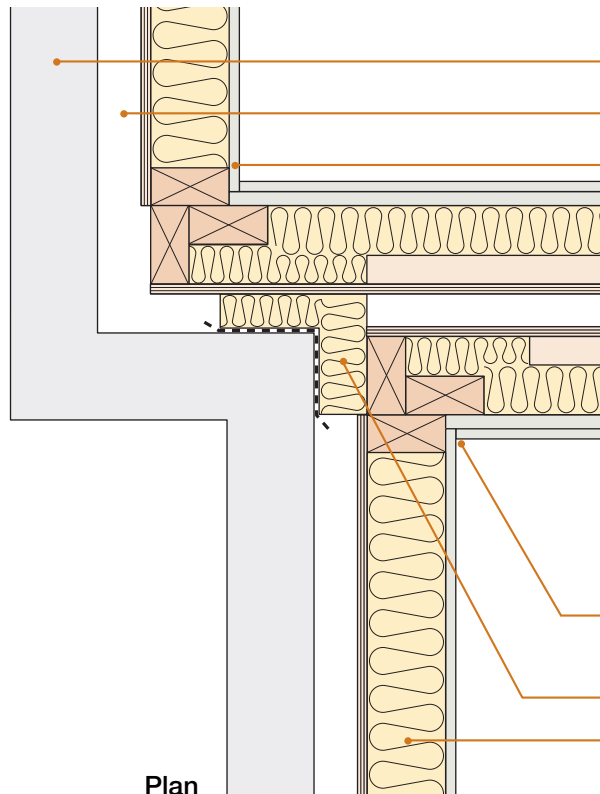

- Masonry outer leaf (min 100mm thick)
- External wall cavity (min 50mm)
- Inner leaf where there is no separating floor e.g. for houses
 - one layer of gypsum-based board nominal 8 kg/m²
- Inner leaf where there is a separating floor, e.g. for flats/apartments
 - if using **robustdetails**[®] for floor, refer to Table 3b in introduction to select an acceptable **robustdetails**[®] separating floor and use two layers of gypsum-based board nominal 8kg/m² each layer
 - if using floor requiring pre-completion testing, seek specialist advice
- Seal all perimeter joints with tape or caulk with sealant
- Close cavity with a cavity stop (see Appendix A)
- Mineral wool insulation 10 kg/m³ (min); 70mm (min) EPS or foil faced PIR with no gaps

Precast concrete plank ■
 Screed laid on Regupol Quietlay or Tekfloor TekRubber resilient layer ■

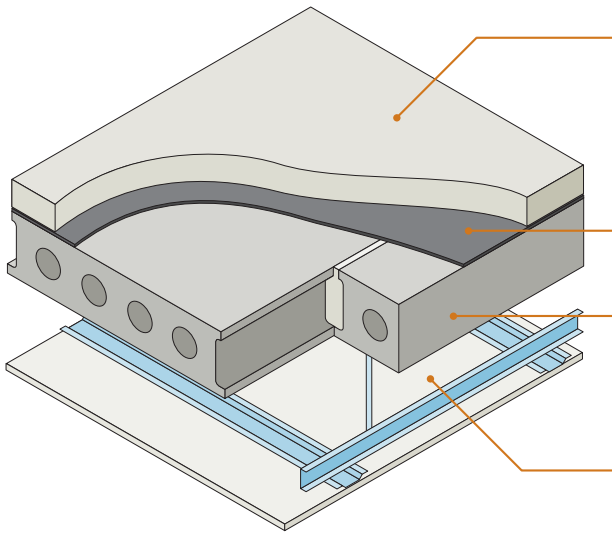

Sketch shows CT0 type ceiling treatment

Screed	65mm (min) cement:sand screed or 40mm (min) proprietary screed of nominal 80 kg/m ² mass per unit area
Resilient layer	Regupol Quietlay or Tekfloor TekRubber
Structural floor	Precast concrete plank of 150mm (min) thickness and 300 kg/m ² (min) mass per unit area
Ceiling	See section 3 for suitable ceiling treatment which is dependent on floor plank depth

SYSTEM INSTALLATION

The use of this screed resilient layer system **must** incorporate the following:

- 1) **Regupol Quietlay** or **Tekfloor TekRubber** (resilient layer to be laid over entire floor area)
- 2) **Regupol Quietlay** or **Tekfloor TekRubber** to be laid with min 100mm upstand at wall (to allow for isolation under wall lining and skirting after screed is poured)
- 3) All joints taped with Regupol Tape or Tekfloor Tape only

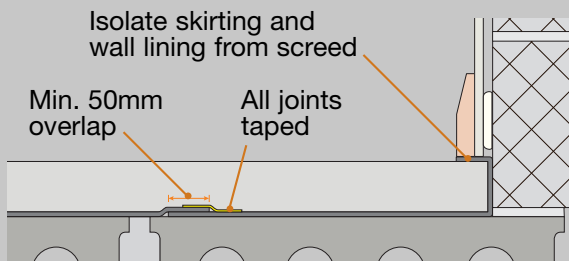

DO

- Butt planks tightly together
- Grout all joints between planks
- Fill all voids between walls and floor
- Ensure resilient layer is laid over entire floor surface with min 100mm upstand at perimeter walls
- Ensure that 'Regupol' or 'TekRubber' is printed on the resilient layer material
- Ensure all joints are taped with Regupol Tape or Tekfloor Tape
- Ensure correct blocks are used in construction of external (flanking) walls
- Make sure ceiling treatment is installed in accordance with the manufacturer's instructions (where applicable)

Robust Details Limited can only accept registration of this floor once the builder agrees to receive training from CMS Danskin on the installation of the screed and resilient layer. Please contact Robust Details Limited for further information.

1. External (flanking) wall junction

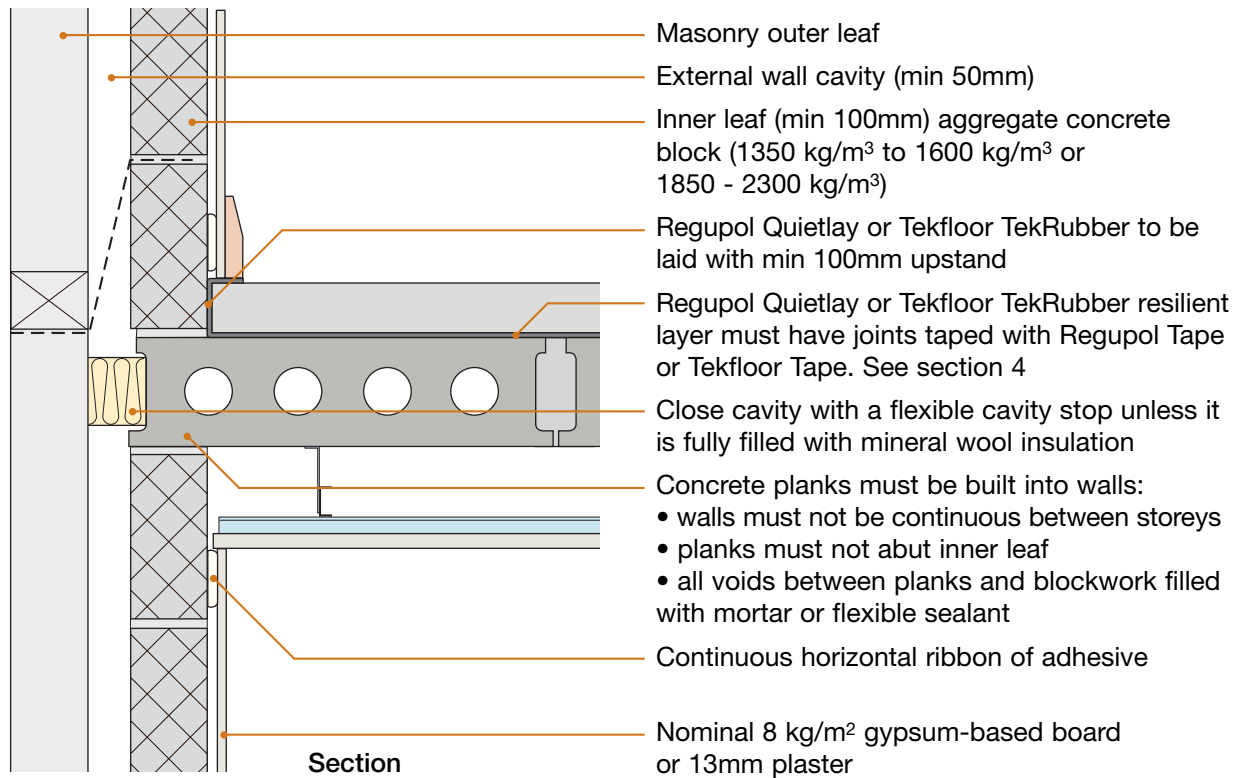

Sketch shows CT0 type ceiling treatment

2. Separating wall junction

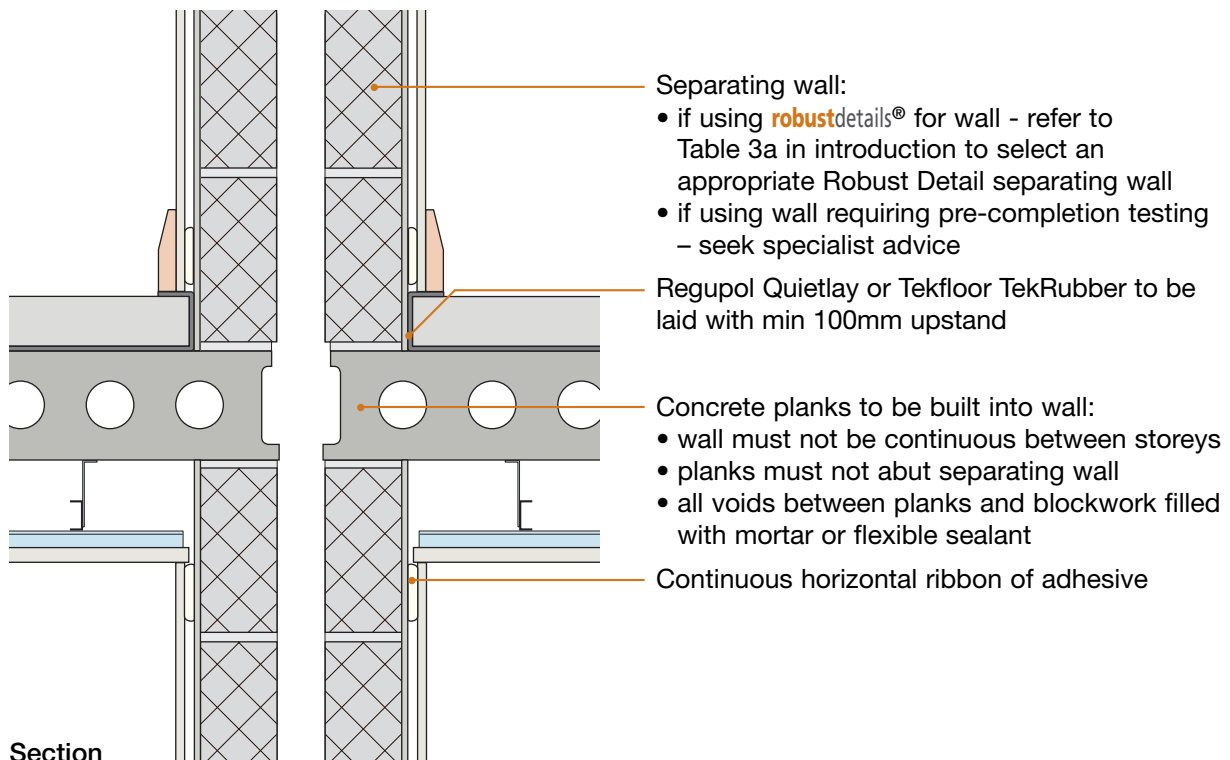

Sketch shows CT0 type ceiling treatment

3. Ceiling treatments for E-FC-15

All ceiling treatments must be installed in accordance with the manufacturer’s instructions. All ceiling joints must be sealed with tape or caulked with sealant.

Note: the sound insulation performance of all ceiling treatments is increased if:

- 25mm (min.) mineral fibre quilt is placed in the ceiling void, and/or
- resilient hangers are used.

Downlighters and recessed lighting

Provided there is a minimum ceiling void as stated below for CT0 or CT1, downlighters or recessed lighting may be installed in the ceiling:

- in accordance with the manufacturer’s instructions
- at no more than one light per 2m² of ceiling area in each room or see Appendix F
- at centres not less than 0.75m
- into openings not exceeding 100mm diameter or 100x100mm

Particular attention should also be paid to Building Regulations Part B - Fire Safety

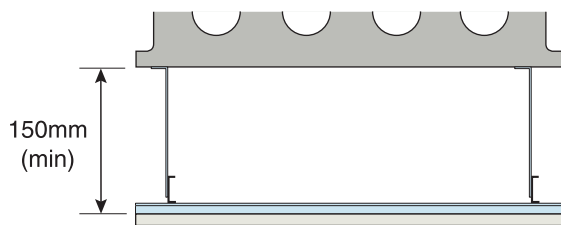

CT0 – Metal ceiling system - 150mm void To be used for 150mm (min) depth concrete planks

- any metal ceiling system providing 150mm (min) ceiling void
- one layer of nominal 8 kg/m² gypsum-based board

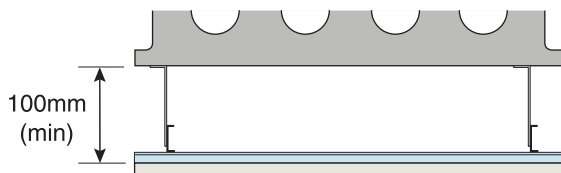

CT1 – Metal ceiling system - 100mm void Only to be used for 200mm (min) depth concrete planks

- any metal ceiling system providing 100mm (min) ceiling void
- one layer of nominal 8 kg/m² gypsum-based board

4. Resilient layer installation for different screed types

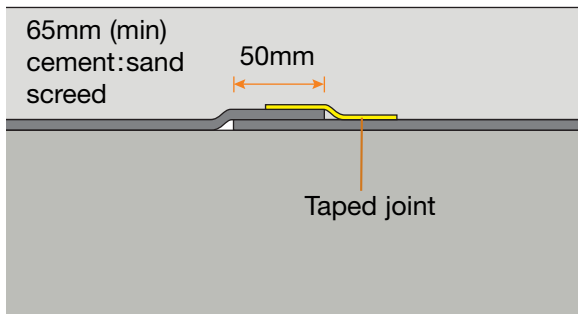

SCREED TYPE

65mm (min) cement:sand screed

- Resilient layer joints to be overlapped by 50mm (min)
- Resilient layer edge joints to be sealed by tape

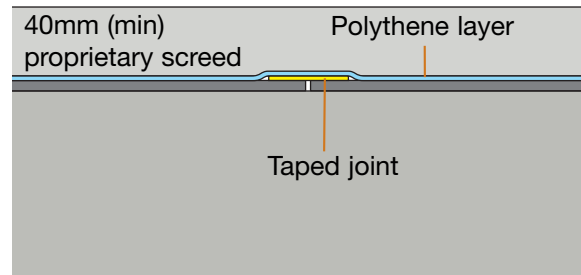

SCREED TYPE

40mm (min) proprietary screed

- Resilient layer joints to be butt jointed
- Resilient layer joints to be sealed by tape
- 500 gauge (min) polythene layer to be laid over whole floor overlapping joints

5. Underfloor heating systems within screeds

Underfloor heating systems (including connectors and fixings) installed within the screed must not penetrate the resilient layer or bridge the screed to the slab.

Underfloor heating systems which have a supporting layer/board may be laid on top of the Regupol Quietlay or Tekfloor TekRubber.

Appropriate screed depth cover to the heating system must be designed for – contact underfloor heating manufacturer for guidance.

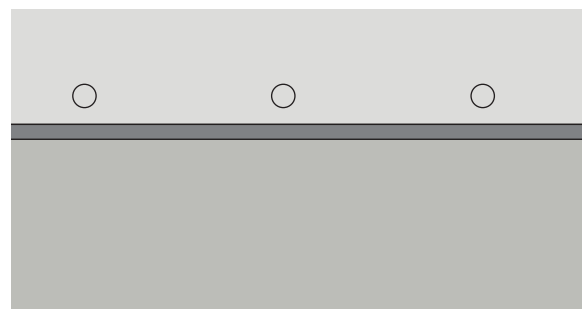

6. Services – Service pipes through separating floor

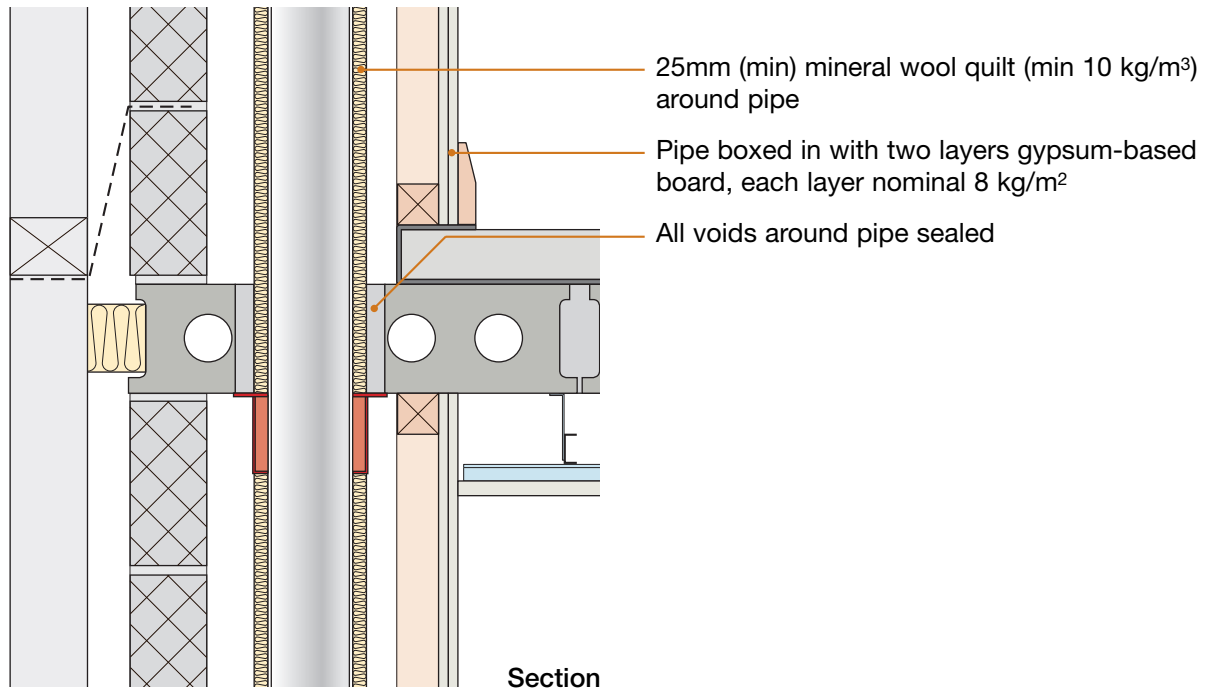

Sketch shows CT0 type ceiling treatment

CHECKLIST (to be completed by site manager/supervisor)

Company: _____

Site: _____

Plot: _____ Site manager/supervisor: _____

Ref.	Item	Yes (✓)	No (✓)	Inspected (initials & date)
1.	Has training been received from CMS Danskin or Tekfloor Ltd	<input type="checkbox"/>	<input type="checkbox"/>	<input type="text"/>
2.	Are precast concrete planks 150mm (min) thick and of mass per unit area 300 kg/m ² (min)?	<input type="checkbox"/>	<input type="checkbox"/>	<input type="text"/>
3.	Are inner leaves to external (flanking) walls of the correct block density?	<input type="checkbox"/>	<input type="checkbox"/>	<input type="text"/>
4.	Are joints between precast concrete planks grouted and sealed?	<input type="checkbox"/>	<input type="checkbox"/>	<input type="text"/>
5.	Are precast concrete planks built into the masonry walls?	<input type="checkbox"/>	<input type="checkbox"/>	<input type="text"/>
6.	Is the Regupol Quietlay or Tekfloor TekRubber covering the whole floor slab?	<input type="checkbox"/>	<input type="checkbox"/>	<input type="text"/>
7.	Is the Regupol Quietlay or Tekfloor TekRubber taken min 100mm up the wall?	<input type="checkbox"/>	<input type="checkbox"/>	<input type="text"/>
8.	Are all joints taped with Regupol Tape or Tekfloor Tape?	<input type="checkbox"/>	<input type="checkbox"/>	<input type="text"/>
9.	Are the skirting boards and wall linings isolated from the screed by the Regupol Quietlay or Tekfloor TekRubber?	<input type="checkbox"/>	<input type="checkbox"/>	<input type="text"/>
10.	Are all ceiling board joints sealed with tape or caulked with sealant?	<input type="checkbox"/>	<input type="checkbox"/>	<input type="text"/>
11.	Are service pipes wrapped in quilt and boxed in with two layers of nominal 8 kg/m ² gypsum-based board?	<input type="checkbox"/>	<input type="checkbox"/>	<input type="text"/>
12.	Is separating floor satisfactorily complete?	<input type="checkbox"/>	<input type="checkbox"/>	<input type="text"/>

Contact details for technical assistance from CMS Danskin, supplier of Regupol Quietlay resilient layer system:
Telephone: 01925 577711 Fax: 01925 577733 E-mail: info@cmsdanskin.co.uk

Contact details for technical assistance from Tekfloor, supplier of TekRubber resilient layer system:
Telephone: 01709 261007 Fax: E-mail: info@tekfloor.co.uk

Notes (include details of any corrective action)

Site manager/supervisor signature

©: UK registered trade mark no. 2291665

© Robust Details Limited 2011. All rights reserved. No part of this Handbook (other than the checklists) may be reproduced in any material form or issued or communicated to the public (including photocopying or storing it in any medium by electronic means, and whether or not transiently or incidentally to some other use of this Handbook) without the prior written permission of Robust Details Limited except in accordance with the provisions of the Copyright, Designs and Patents Act 1988.

Warning: the doing of an unauthorised act in relation to a copyright work may result in both a civil claim for damages and criminal prosecution.

Timber I-Joists ■
Use with timber frame walls only ■

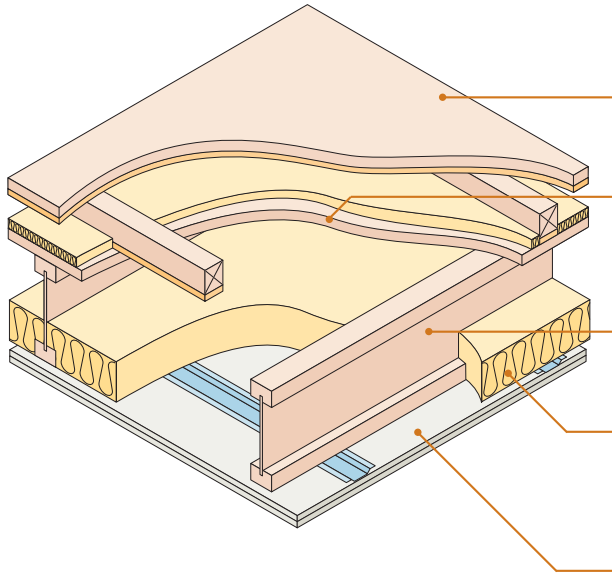

Floating floor	See section 6 for suitable floating floor treatment
Floor decking	15mm thick (min) wood based board, density 600 kg/m ³ (min)
Joists	235mm (min) timber I-Joists
Absorbent material	100mm (min) mineral wool quilt insulation (10–36 kg/m ³) between joists
Ceiling	See section 5 for suitable ceiling treatment

Note: Structural framing details may vary slightly between different manufacturers and this is permitted, however, all dimension specifications within this Robust Detail must be adhered to.

DO

- Lay quilt (min 100mm thick) between all joists, including doubled up I-joists, ensuring no gaps remain
- Ensure floating floor treatment is suitable and is installed in accordance with the manufacturer's instructions
- Ensure quilt is laid between and not under flooring battens
- Install flanking strips around the perimeter of the flooring board to isolate floor from walls and skirtings
- Ensure resilient ceiling bars are fixed at right angles to the joists
- Ensure timber floor ceiling treatment is either CT1, CT2 or CT3 and is fixed correctly (see page 4)
- Stagger joints in ceiling layers
- Refer to Appendix A

1. External (flanking) wall junction

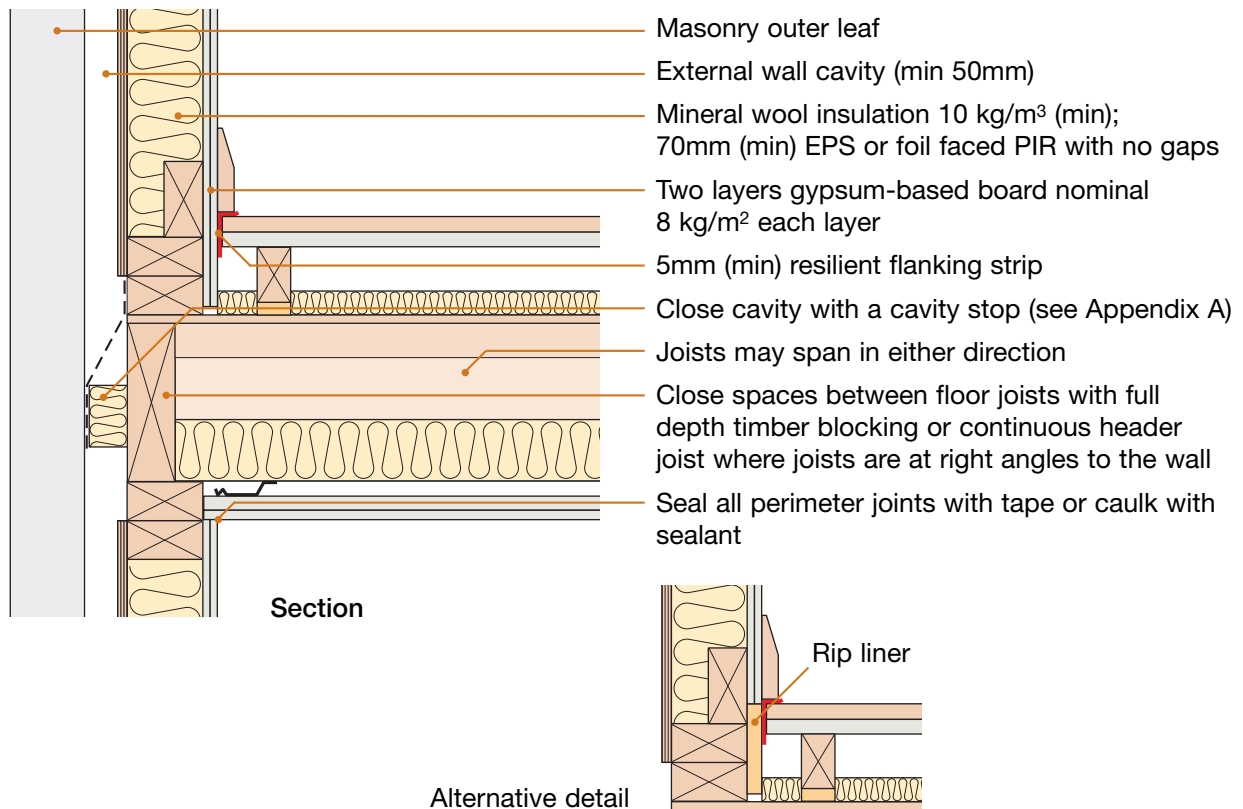

2. Separating wall junction

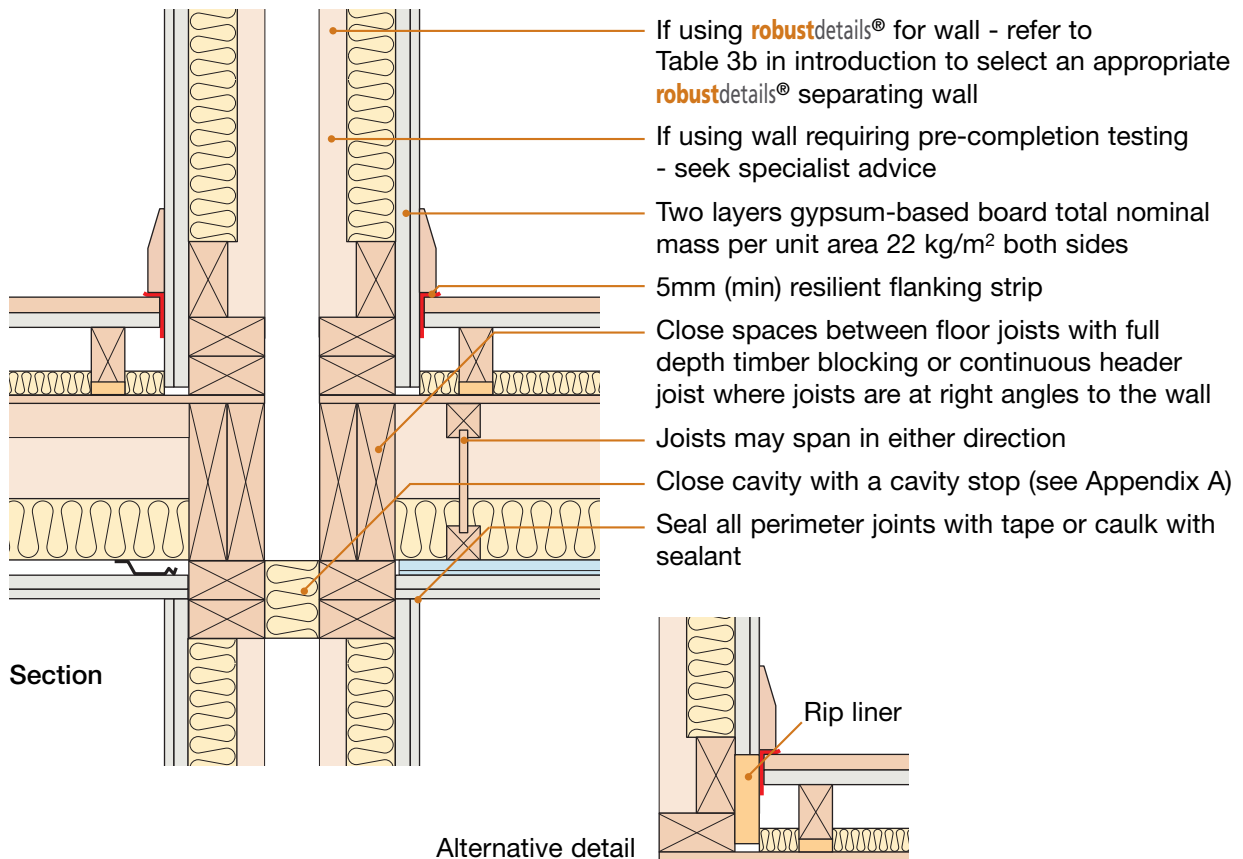

Appendix A1 – Additional Guidance

Contents

Section	Page
Wall ties in cavity masonry separating walls	1
Wall ties in cavity masonry external walls	1
Cavity stops	2
Cavity trays	2
Movement joints in cavity masonry separating walls	2
Bed joint reinforcement	3
Internal floor joists/floor beams and masonry separating walls	3
Structural steelwork in masonry separating walls	4
Concrete beam and block ground and internal floors	4
Coursing in blockwork separating walls	4
Flues in separating walls	4
Internal render	4
Services and chases in separating walls	4
Spandrel panels	5
Room-in-roof - requirements for gypsum-based boards	5
Gypsum-based board	5
Cavity masonry separating walls – staggered external (flanking) wall junction	6
Roof junctions – thermal insulation	6
Building Regulations Part A (2004)	6
Internal walls (minimum mass requirements)	6
Junctions between internal partition walls and separating floors	6
Subfloor ventilation	7
Radon and methane barriers	
Ground floor junctions	7
Screed thickness	7
Precast concrete plank separating floors with steel beams	7
Services in separating floors	8
Underfloor heating systems in separating floors	8
Resilient bars	9
Timber floating floor treatments	9
Floating floor treatments in kitchens and bathrooms	9
Laminated or ceramic flooring on separating floors	9
Screed floating floor treatments	9
Masonry angle supports	9
Full height glazing units junction with robust details® separating floors	9
Specification requirements	10
Lifting holes in cassette floors	10

Wall ties in cavity masonry separating walls

Only “type A” wall ties are suitable for use with masonry cavity separating wall Robust Details.

Approved Document E clause 2.19 describes the requirements for Tie Type A (separating walls) as follows:

Tie type A

Connect the leaves of a masonry cavity wall only where necessary by butterfly ties as described in BS 1243: 1978 Metal ties for cavity wall construction, and spaced as required for structural purposes (BS 5628-3: 2001 Code of practice for use of masonry. Materials and components, design and workmanship, which limits this tie type and spacing to cavity widths of 50mm to 75mm with a minimum masonry leaf thickness of 90mm). Alternatively, use wall ties with an appropriate measured dynamic stiffness for the cavity width. The specification for wall ties of dynamic stiffness, k_{xmm} in MN/m with a cavity width of X mm and n ties/m² is $n.k_{xmm} < 4.8$ MN/m³.

When using wall ties for masonry separating walls the specifier should ensure that the wall tie manufacturer has a test report that demonstrates compliance with the required ADE criteria.

Wall ties in cavity masonry external walls

In relation to the wall tie requirements for external walls tie “Type A” may be used if it satisfies the requirements of Building Regulation Part A – Structure. However, where tie “Type A” does not meet these requirements for external walls tie “type B” wall ties should be used.

Approved Document E clause 2.20 describes the requirements for Tie Type B (external walls) as follows:

Tie type B

Connect the leaves of a masonry cavity wall only where necessary by double-triangle ties as described in BS 1243: 1978 Metal ties for cavity wall construction, and spaced as required for structural purposes (BS 5628-3: 2001 Code of practice for use of masonry. Materials and components, design and workmanship, which limits this tie type and spacing to cavity widths of 50mm to 75mm with a minimum masonry leaf thickness of 90mm). Alternatively, use wall ties with an appropriate measured dynamic stiffness for the cavity width. The specification for wall ties of dynamic stiffness, k_{xmm} in MN/m with a cavity width of X mm and n ties/m² is $n.k_{xmm} < 113$ MN/m³.

Appendix A1 – Additional Guidance

Cavity stops

The flexible cavity stops at the junction of the separating wall and the external (flanking) wall are shown in the Robust Details as a single piece of material (diagram a). It is acceptable for these to be provided as two separate pieces (diagram b), or three separate pieces (diagram c).

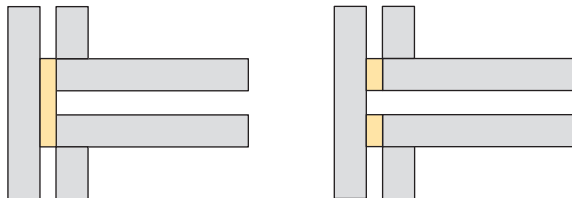

Diagram a

Diagram b

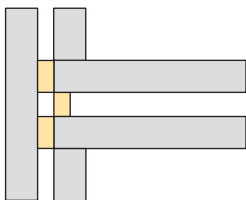

Diagram c

The following types of cavity stop may be used:

- single mineral wool batt cavity stops
- dual rigid cavity stops on either side of the external wall cavity (not for masonry separating walls)
- single rigid cavity stop attached to one leaf of the separating wall only (not for masonry separating walls)
- flexible single cavity stop such as the mineral wool “tubular style”
- flexible double cavity stops such as the mineral wool “tubular style” where one is fitted in line with each leaf of the separating wall.

Single rigid cavity stops which structurally couple both leaves of the separating wall are not permitted.

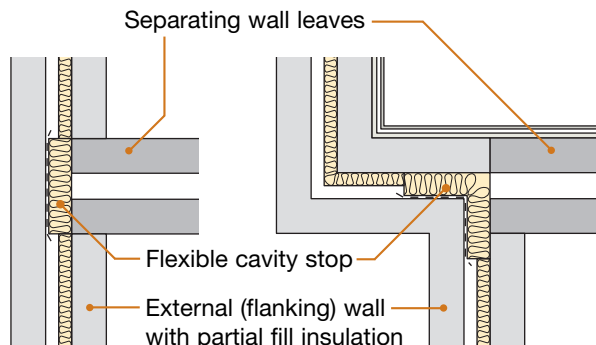

Diagram d

Partial fill insulation should be installed up to the cavity stop.

Cavity trays

The cavity trays shown above the cavity stops are included for illustrative purposes only and not for acoustic reasons.

Movement joints in cavity masonry separating walls

Separating walls with a gypsum-based board finish

Where possible, movement joints should be avoided in separating walls with a gypsum-based board finish. Where they are essential, they should be formed as follows:

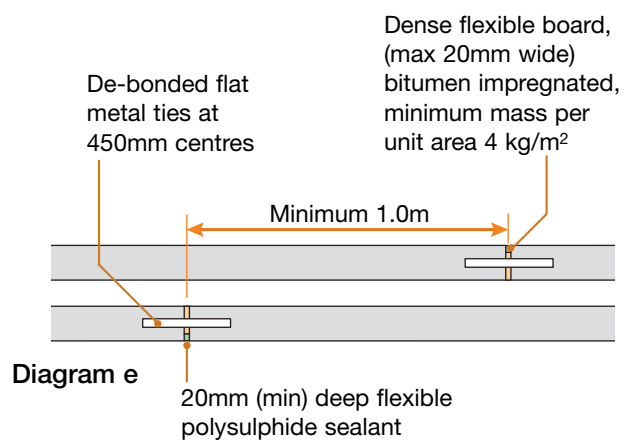

Diagram e

Where possible, movement joints should be located in bathrooms or other minor rooms or behind cupboards, etc.

Separating walls with wet plaster finish

Movement joints are not acceptable in **robustdetails**[®] separating walls with a wet plaster finish unless they are strategically placed behind internal wall junctions or service pipe casings.

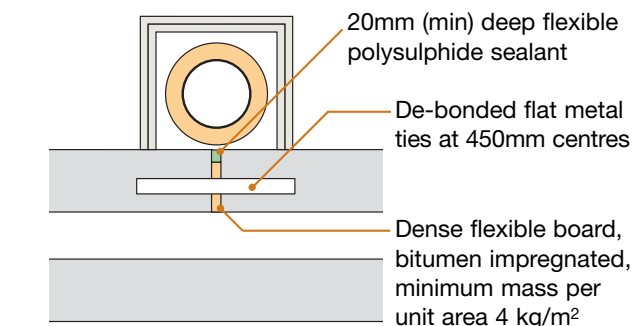

Diagram f

The movement joints must also be staggered and spaced not less than 1m apart, as shown in Diagram d above.

Appendix A1 – Additional Guidance

Bed joint reinforcement

It is acceptable to install masonry reinforcement within the horizontal bed joints of the cavity masonry separating provided:

- the masonry reinforcement is contained wholly within the mortar bed joint of each individual leaf of masonry
- the masonry reinforcement does not connect the two leaves of the cavity walls together or bridge the cavity in any way

Internal floor joists/floor beams and masonry separating walls

Internal floor joists at right angles to the separating wall may be supported by metal joist hangers or be built into the wall.

The acoustic performance of separating walls is adversely affected by any gaps in the masonry as these provide a direct sound transmission path. **It is essential that joists and beams are built in only if a high standard of workmanship can be guaranteed.**

Solid timber joists

Solid timber joists may be built into the separating wall, provided that:

- the mortar joints around each joist perimeter are recessed or struck, and
- the joint between the masonry and the timber is carefully pointed with silicone sealant.

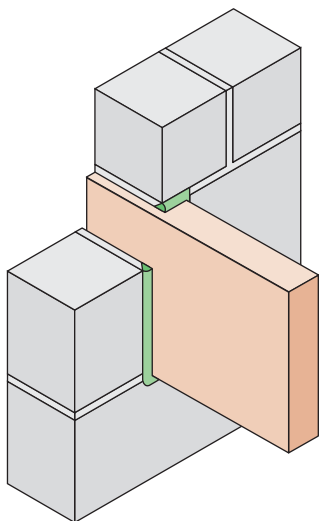

Alternatively, proprietary joist caps/ends designed to satisfy the air leakage requirements of Approved Document L1 may be used. They should be installed in accordance with the manufacturer's instructions.

In circumstances where the joist end cap is larger than the depth of the joist, such that there is a gap between the top of the joist and the joist end cap, this should be filled with mineral wool or other suitable material such that the acoustic performance of the wall is maintained.

Metal web joists

Metal web joists may be built into the separating wall following the guidance for solid timber joists above. Metal web joists must have solid ends.

Timber I-Joists

Timber I-joists may be built into the separating wall, provided that:

- proprietary filler pieces are fitted on both sides of the web between the top and bottom flanges. These filler pieces must not damage the joist flanges - their depth should be slightly less than the dimension between the joist flanges to achieve a "loose fit".
- the mortar joints around each joist perimeter are recessed or struck, and
- the joint between the masonry and the timber and any other air paths are carefully pointed with silicone sealant.

Alternatively, proprietary joist caps/ends designed to satisfy the air leakage requirements of Approved Document L1 may be used. They should be

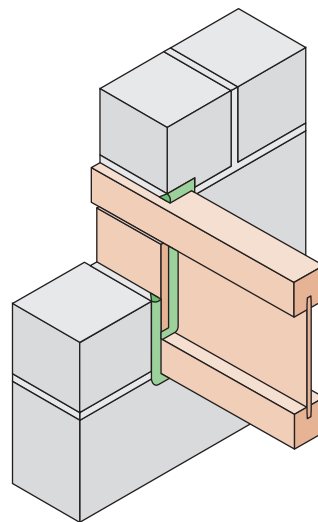

installed in accordance with the manufacturer's instructions. In circumstances where the joist end cap is larger than the depth of the joist, such that there is a gap between the top of the joist and the joist end cap, this should be filled with mineral wool or other suitable material such that the acoustic performance of the wall is maintained.

Appendix A1 – Additional Guidance

Steel beams

Steel beams may be built into the leaf of a cavity separating wall, provided that all voids around the beam ends are filled with mortar or flexible sealant.

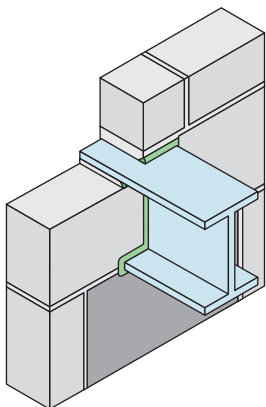

Separating walls should not be constructed off steel beams.

Structural steelwork in masonry separating walls

Steel columns built into masonry separating walls are not permitted.

Separating walls should not be constructed off steel beams.

Concrete beam and block ground and internal floors

Concrete beam and block floors may be built into the separating wall, provided:

- all voids are carefully filled with mortar
- the floor does not bridge the cavity leaves.

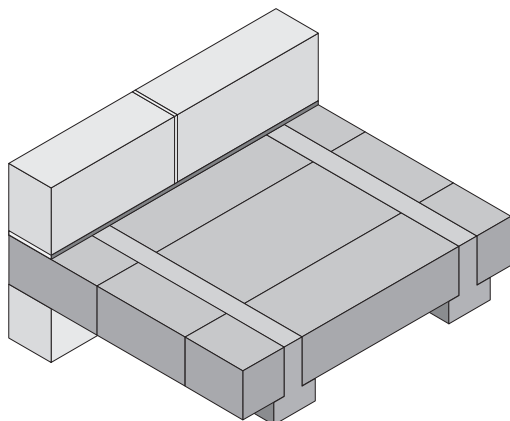

Coursing in blockwork separating walls

For the purposes of adjusting coursing it is permissible to use smaller units of **robustdetails**[®] separating wall material (e.g. brick sized), provided the density of the smaller units is at least the same as the separating wall material.

Flues in separating walls

Flue blocks may not be built into the separating wall where the finish is wet plaster. Flue blocks may only be built into the normal width of a separating wall where a diagram is included in the Robust Details.

Any of the **robustdetails**[®] masonry separating walls with gypsum-based board on dabs finish, may use the following alternative detail:

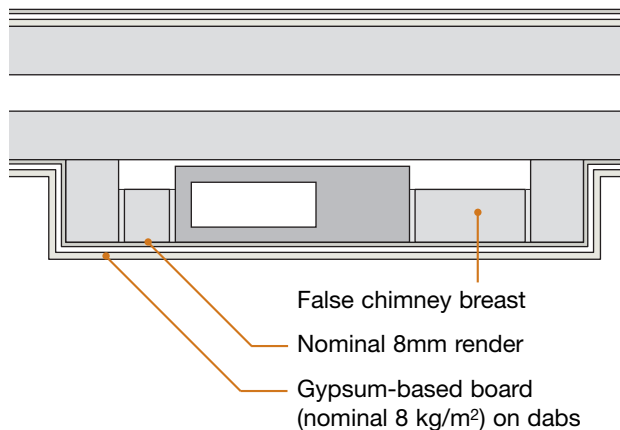

Internal render

Some of the Robust Details for masonry separating walls indicate the use of an internal render (parge) coat prior to the application of dry lining. Where a cement:sand render coat is used it should not be float or skim finished but preferably applied in an uneven manner with a trowel (or equivalent) and scratch finished.

Internal render may be omitted from the following locations:

- wall surfaces not facing into a room
- floor joist/beam zone
- roof space (where there are no rooms in the roof)
- staircases may be installed prior to the application of render, and the render and gypsum-based board are not required behind the stair string.

Mixes quoted are for cement, lime and sand by volume based on damp sand. Mixes made with cement, sand and plasticiser are also acceptable.

Services and chases in separating walls

Where possible, services should not be built into the separating wall.

However, where chasing is permitted in the Detail, they should be kept to a minimum. Chases must not be located back to back. Care must be taken to ensure all voids are fully filled with mortar. Where conduits or cappings are used they should not be in contact with the gypsum-based board.

The Robust Details for timber and steel framed walls show how services should be built in.

Appendix A1 – Additional Guidance

Spandrel panels

Where stated in the Robust Detail spandrel panels are an acceptable alternative to building the cavity separating wall in the roof space (without room-in-roof).

When adopting spandrel panels particular attention should be paid to Building Regulations Part B - *Fire Safety*, the dimensions given below are the minimum required to maintain only the acoustic integrity.

The spandrel panel should comprise:

2 layers of nominal 8 kg/m² gypsum-based board or 1 layer of 15mm Fermacell board each side of a 35x45mm (min.) timber or lightweight steel frame.

Masonry construction

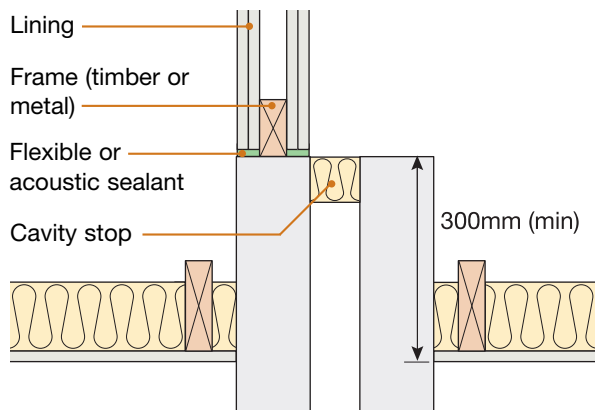

The supporting blockwork should extend at least 300mm above the finished ceiling layer. The top of the cavity wall should be closed with a cavity stop. The junction between the spandrel panel and supporting blockwork should be sealed with flexible or acoustic sealant. Alternatively, the spandrel panel may be mounted on a layer of mineral wool.

The linking of wall leaves by spandrel panels is not permitted.

Timber frame construction

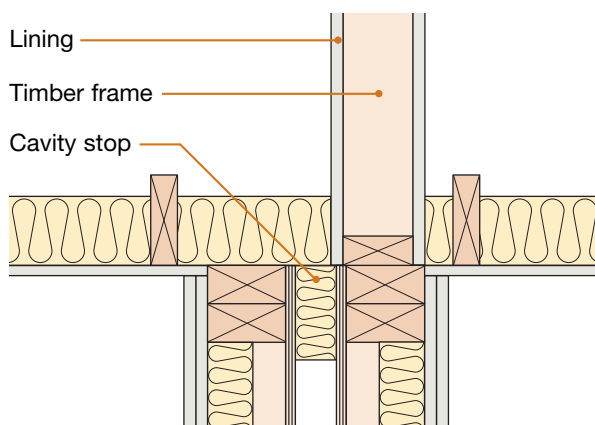

Two panels may be adopted provided a 50mm (min.) cavity is maintained between the sheathing faces, or the stud frames where no sheathing is fitted.

Room-in-roof – requirements for gypsum-based boards

Room-in-roof constructions are permitted only where stated in the Robust Detail. Where the ceiling to the room is directly beneath the roof structure, typically the sloping areas, two layers of gypsum-based board are required, as per the relevant room-in-roof detail for the adopted separating wall. A single layer of gypsum-based board may be adopted in other areas.

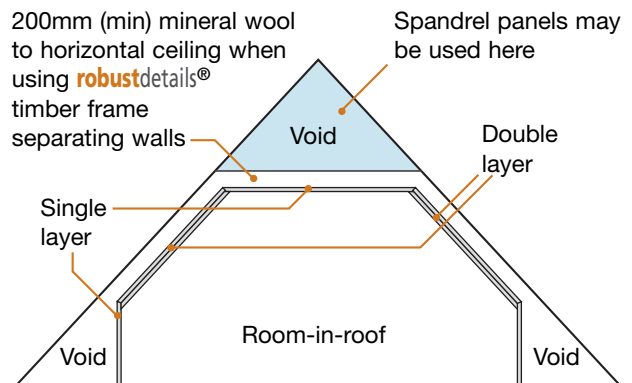

Section through room-in-roof

Gypsum-based board

Gypsum-based boards may be either plaster gypsum-based or cement gypsum-based.

The mass per unit area or surface density specified is a nominal minimum value in kilograms per square metre (kg/m²): the use of a higher density board will increase the sound insulation performance.

Boards should be abutted and all joints sealed with tape or caulked with sealant. Where two or more layers of gypsum-based board are required on separating walls or ceilings all joints should be staggered, and only the outer layer boards need to be sealed with tape or caulked with sealant. The order in which boards are fitted and lapped is not critical provided the overall mass per unit area is maintained. The same applies to combined render/plaster finishes.

Boards fitted to steel and timber frame separating walls should be mounted in accordance with the manufacturer's instructions – some boards may need to be mounted horizontally.

Thermal laminate boards may be used as the wall finish to masonry walls, provided the nominal mass per unit area indicated in the Robust Detail is maintained - seek advice from the manufacturer.

An acceptable alternative to caulking or sealing the joint between the wall and the ceiling is to use gypsum coving.

Appendix A1 – Additional Guidance

Cavity masonry separating walls – staggered external (flanking) wall junction

As an alternative to the junction shown in the Robust Detail, it is acceptable for the inner leaf blockwork to extend to the inner face of the external wall cavity, as shown below.

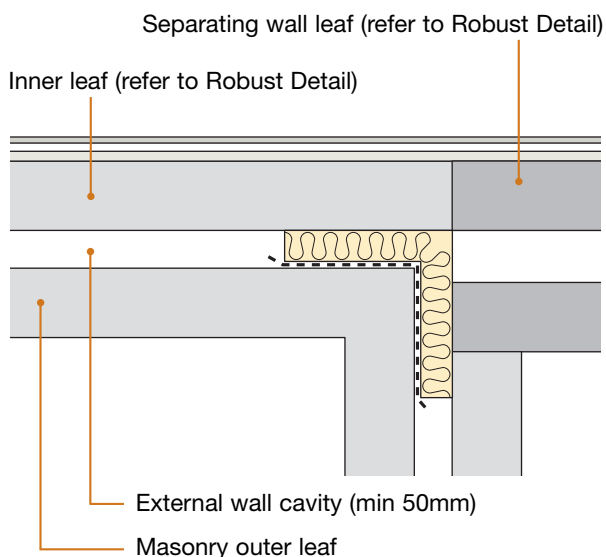

Roof junctions – thermal insulation

Additional layers of thermal insulation may be added as follows:

100mm (min) mineral wool insulation minimum density 10 kg/m³ or 60mm (min) foil faced PUR or PIR insulation, minimum density 30 kg/m³

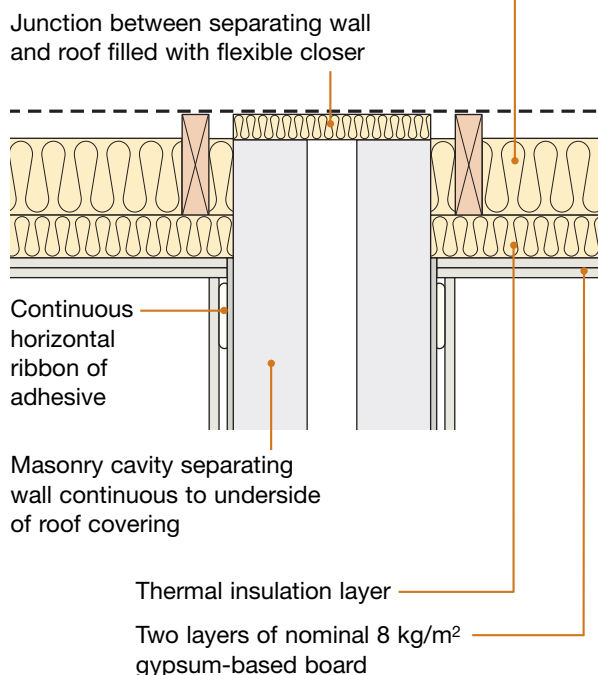

Building Regulations Part A (2004) – disproportionate collapse

Masonry construction

Lateral restraint straps may be used at floor junctions, roof level and other junctions, if necessary to meet the requirements of Part A, provided they do not bridge the cavity separating wall leaves and that no voids remain at the mortar joints.

Internal walls (minimum mass requirements)

Junctions with cavity masonry separating walls

- masonry internal walls where there is no separating floor (e.g. houses) – no restrictions
- masonry internal walls where there is a separating floor (e.g. flats/apartments) – internal wall should have a minimum mass per unit area of 120 kg/m² (including the finish) OR at least that of the approved flanking wall inner leaf, if this is less.
- timber frame and steel frame internal walls – no restrictions.

Junctions with timber and steel frame separating walls

No minimum mass requirements.

Junctions with concrete or steel-concrete composite separating floors

- masonry internal walls – internal wall should have a minimum mass per unit area of 120 kg/m² (including the finish) OR at least that of the approved flanking wall inner leaf, if this is less.
- timber frame and steel frame internal walls – no restrictions.

Junctions with timber or light steel separating floors

No minimum mass requirements.

Junctions between internal partition walls and concrete separating floors

The junction between internal partition walls and concrete separating floors should be formed as follows:

1. Install internal lightweight stud partitions either up to the ceiling lining or through the ceiling lining, provided the head channel of metal stud partitions or timber frame, as appropriate, fully seals the void between the wall linings, such that there are no air paths from the ceiling void to the partition void.
2. Install loadbearing masonry internal partition walls up to the underside of the floor, provided the floor is continuous over the wall and the wall has a minimum mass per unit area of 120kg/m² (including the finish) OR at least that of the approved flanking wall inner leaf, if this is less.

Appendix A1 – Additional Guidance

- Construct the internal wall directly off core floor with the floating floor treatment (FFT) or screed installed around the internal walls, provided:
 - the 5mm (min) resilient flanking strip or isolating edge strip, as appropriate for the Robust Detail adopted, is correctly installed to all perimeters of the FFT or screed to isolate the floor from all the walls and skirtings
- Construct the internal wall off the floating floor treatment flooring board or screed, provided:
 - the floating floor treatment is installed in accordance with the manufacturer's instructions, including the provision of additional battens to support the internal walls if necessary

Subfloor ventilation

Where possible it would be preferable to avoid providing ventilation for the sub floor void through the separating walls.

However, where necessary, the ventilation of the sub floor void of Part E Robust Detail separating walls may be achieved through the installation of ducts through the separating wall, provided:

- the top of the duct is at least 300mm below the finished floor surface of the ground floor structure
- the number of ducts passing through the separating wall is kept to the minimum necessary.

Radon and methane barriers

It is acceptable to install a radon or methane barrier and comply with the Robust Details. The ground floor junction detail would need to follow that described in the Robust Detail and as such the 225mm (min) clear cavity indicated in the ground floor junction to masonry separating walls would need to be maintained. Alternatively, refer to Appendix A2.

Ground floor junctions

5mm (min) flanking strips are recommended to isolate floating floor finishes, where provided, from walls and skirtings.

Screed thickness

The screed thickness stated is the minimum thickness at any point and a greater thickness should be specified to take account of deviations in the finished levels of the surfaces of bases and any reinforcement provided.

Cement:sand screed should be at least 50mm to comply with BS 8204. Concrete screed is acceptable.

Precast concrete plank separating floors with steel beams

In some situations precast concrete planks may require intermediate support by steel beams supported on masonry.

- cavity masonry separating walls must not be built off steel beams – where necessary, external cavity walls may be built off steel beams
- all voids between the steel beam and the slabs should be fully filled with grout or concrete, and
- the supports for the ceiling treatment and the ceiling lining should not come into contact with the steel beam, and
- the depth of the ceiling void from the underside of the plank should be as shown in the following diagrams and in accordance with the corresponding separating floor Robust Detail
- mineral wool quilt should be provided if shown in the following diagrams

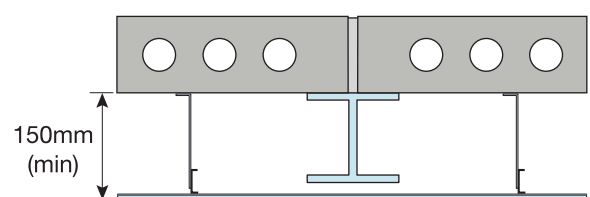
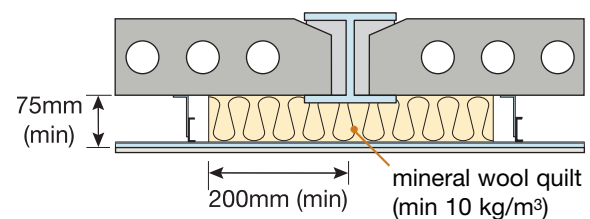
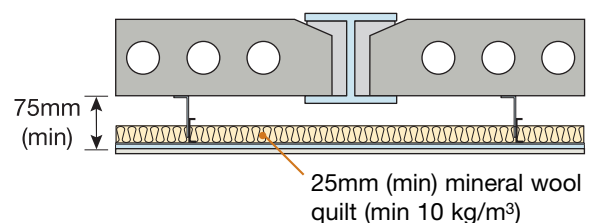
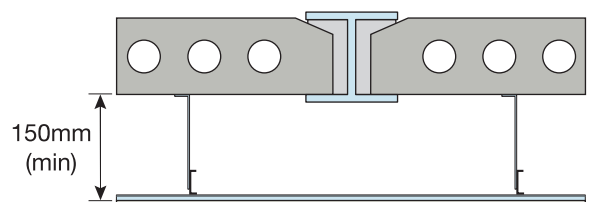

Appendix A1 – Additional Guidance

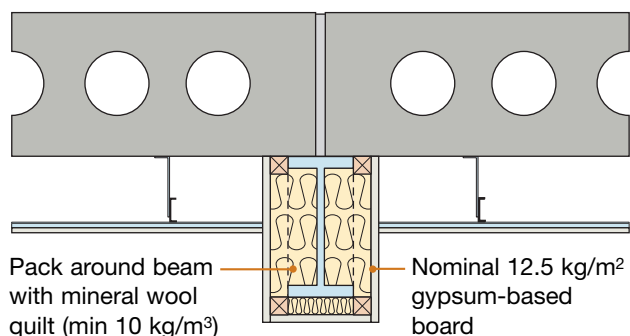

An alternative detail where two steel beams are required to support the external cavity wall is as follows:

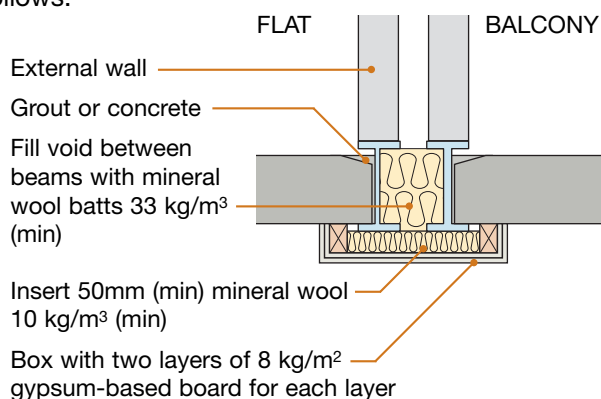

Separating walls should not be constructed off steel beams.

Services in separating floors

Downlighters or recessed lighting

Where possible, downlighters or recessed lighting should not be built into the separating floor. If they must be built in, they should be kept to a minimum and the guidance included in the Robust Detail followed. For timber separating floors, see Appendix F also.

Particular attention should also be paid to Building Regulation Part B – Fire Safety.

Other services

Electrical and plumbing services may be installed in the separating floor. All penetrations through the ceiling lining, floor decking and flooring board should be cut carefully. The gap around the service should be carefully sealed with flexible sealant.

Where services are installed within a floating floor treatment, the manufacturer's instructions should be followed. It is acceptable to leave a gap of up to 50mm in the batten to allow services to cross at right angles.

Ducts for extract ventilation, etc. may run within the separating floor, provided the acoustic integrity is maintained.

Ducting which drops from the ceiling void needs to be enclosed in boxing of gypsum-based board of the same composition and mass per unit area as the relevant Robust Detail ceiling treatment.

It is permissible to install services within the screed of concrete floors, provided that:

- the minimum thickness and mass per unit area of the screed is maintained as detailed in the relevant Robust Detail
- the minimum cover on services is maintained
- the services do not break into or bridge the resilient layer(s). In the case of floors which also have a floating timber floor treatment (FFT), it is permissible for services to rise vertically out of the screed and through the FFT, provided the FFT flooring boards do not touch the services and the gaps around the services are sealed with a flexible sealant.

Services may be installed within a secondary ceiling lining system that is only supported from the resilient bars of a ceiling treatment, provided:

- the resilient bars can support the full load;
- the resilient bars achieve the minimum laboratory performance of Appendix E.

Particular attention should also be paid to Building Regulations Part B – Fire Safety. Secondary ceilings to timber floors may also be supported by perimeter channels.

Underfloor heating (UFH) systems in separating floors

With timber floating floor treatments

UFH may be fitted between the battens of FFT1, FFT2 and FFT3; or underneath FFT4 or FFT5. UFH may only be incorporated within FFT4 or FFT5 provided the complete build-up, using all intended components, has been tested to Appendix D.

Where underfloor heating is supported by mineral wool or foil-wrapped quilt, this may be used in place of the mineral wool that is specified between the battens on certain floors. Where underfloor heating is supported on rigid insulation (e.g. polystyrene), this may be used in addition to the mineral wool specified on certain floors. If this results in the batten void being filled, a polythene layer should be included to prevent direct contact with the underside of the floating deck. On floors where no mineral wool is specified, rigid insulation may be used alone, provided it does not bridge the resilient layer by providing a connection between the structural floor and any of the floating elements.

With floating screed floors

If underfloor heating systems are required to be installed within the screed they must not penetrate through the resilient layers and must avoid bridging the screed to the slab. Where rigid insulation

Appendix A1 – Additional Guidance

boards are used which have surface indents for the heating conduits to be situated within, this is acceptable. For floors that incorporate an insulation layer, such indented boards may be used as part of the resilient layers, provided they are of an appropriate type of material, and that the minimum thickness of the resilient layer is maintained.

Resilient bars

When using resilient bars the specifier should ensure that the resilient bar manufacturer has a laboratory sound test report (as outlined in Appendix E) that demonstrates compliance with the **robustdetails**[®] performance criteria.

Timber floating floor treatments

When using timber floating floor treatments (e.g. battens, cradles, platforms) the specifier should ensure that the floating floor treatment manufacturer has a laboratory sound test report (as outlined in Appendix C or D) that demonstrates compliance with **robustdetails**[®] performance criteria.

It may be necessary for battens to be installed at closer centres or for additional support to be provided under heavy loads from internal walls, sanitary ware and kitchen units, etc. in accordance with the manufacturer's instructions.

The floating floor treatment must cover all areas where footfall may occur.

Rigid insulation boards (e.g. expanded, extruded or bead polystyrene) are not acceptable for use as the resilient layer or as a flanking strip with a floating floor treatment where the walking surface is board based.

Mineral wool may not be used as a resilient flanking strip. See Appendix B, Glossary, for definition of a resilient flanking strip.

Floating Floor Treatments in kitchens and bathrooms

It is permissible to install kitchen units and appliances along with bathroom sanitary fittings directly onto the sub floor construction. In all cases it is recommended that you contact the manufacturer directly to seek their advice relating to the specific FFT.

Laminated or ceramic flooring on separating floors

In principle it is acceptable to install laminate timber floor finishes on top of the timber floating floor treatments (FFT's) indicated in Part E Robust Details, provided:

- the manufacturer of the FFT system confirms that the performance of the FFT will not be affected;

- any specific guidelines, regarding the installation of such finishes, stipulated by the manufacturer of the FFT system are strictly followed;
- the laminate timber floor finish does not bypass the isolation provided by the flanking strips at the perimeters of the FFT by being in direct contact with the wall or skirting;

In the case of the Part E Robust Details with floating screed, it would also be acceptable in principle to provide a laminate timber floor finish, provided:

- the laminate timber floor finish does not bypass the isolation provided by the isolating edge strips at the perimeters of the screed by being in direct contact with the wall or skirting;

Screed floating floor treatments

Where screeds are separated from the core floor by resilient layers the screed must be fully isolated from the floor slabs, perimeter walls and skirtings and must not come into direct contact with these areas. The resilient layer(s) should completely cover the core floor surface including into doorways and reveals and be wrapped round the edge of the screed to isolate the screed from the perimeter walls and skirtings.

Masonry angle supports

The masonry outer leaf of external walls used with **robustdetails**[®] concrete or steel-concrete composite separating floors, may be supported on suitable proprietary masonry angle supports that are fixed to the edge of the separating floors.

Full height glazing units junction with **robustdetails**[®] separating floor

If referred to in the detail, full height glazing units may be used. Where there is no inner leaf and a full height glazing unit, the core floor slab must break the vertical continuity of the glazing facade, as shown below.

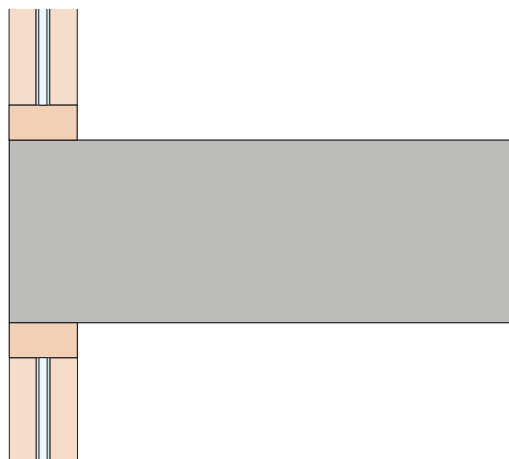

Appendix A1 – Additional Guidance

Specification requirements

Where details have “minimum” in their specification, it indicates that the value should not be lower than that stated. It does not preclude the use of higher values.

For example, where a 75mm (min) cavity size is specified, it does not preclude the use of wider cavities. Similarly, a reference to a wall finish with 8 kg/m² gypsum-based board does not preclude the use of boards with a greater mass per unit area.

Lifting holes in cassette floors

The required acoustic performance of any of the **robustdetails**[®] timber or steel frame separating floors would not be affected if lifting holes within the sub-deck remain untreated, provided:

- each lifting hole is no larger than 120mm in diameter
- mineral wool quilt, of the appropriate specification as indicated in the relevant separating floor specification, is provided covering the whole area of the floor, between the joists/battens, in both the structural floor void and the floating floor void
- all other relevant requirements are strictly followed.

Lifting holes that are larger than 120mm in diameter should be sealed or covered with a board or panel of similar or greater density than the sub-deck board.

Appendix A2 – Proprietary Flanking Conditions

Contents

Section	Page
Icopal-MONARFLOOR® BRIDGESTOP® System for robustdetails ® masonry cavity walls	2
Smartroof complete Interlocking “room-in-roof” panel system using robustdetails ® timber or masonry cavity walls	3
Kingspan TEK inner leaf flanking condition for robustdetails ® timber separating walls	4
Prestoplan PresPeak 60 interlocking single spandrel panel system for robustdetails ® timber separating walls	5
Icopal-MONARFLOOR® Wall Cap RDA2 System for robustdetails ® separating floors with cavity flanking walls	6
RoofSpace I-Roof™ “room-in-roof” panel system using robustdetails ® timber or masonry cavity walls	7
Space4 “room-in-roof” panel system using robustdetails ® timber or masonry cavity walls	8
Stewart Milne Timber Systems Sigma® Roof Spandrel Panel System for robustdetails ® timber separating walls	9
NYTROOF RAPID FIT SYSTEM for robustdetails ® masonry cavity walls	10
Lightweight external cladding for robustdetails ® timber separating walls	11

Appendix A2 – Proprietary Flanking Conditions

Icopal-MONARFLOOR® BRIDGESTOP® System for robustdetails® cavity masonry walls.
Refer to Table 6 in Introduction.

1. Separating wall – direct support on raft

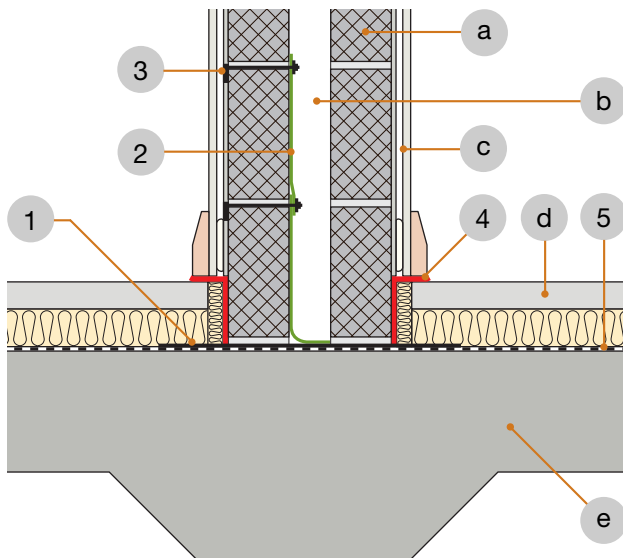

2. Separating wall – suspended floor with gas membrane

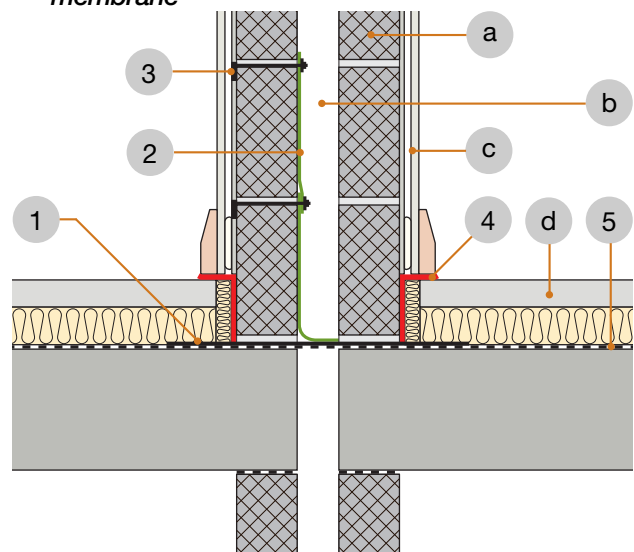

3. Insulated raft foundation

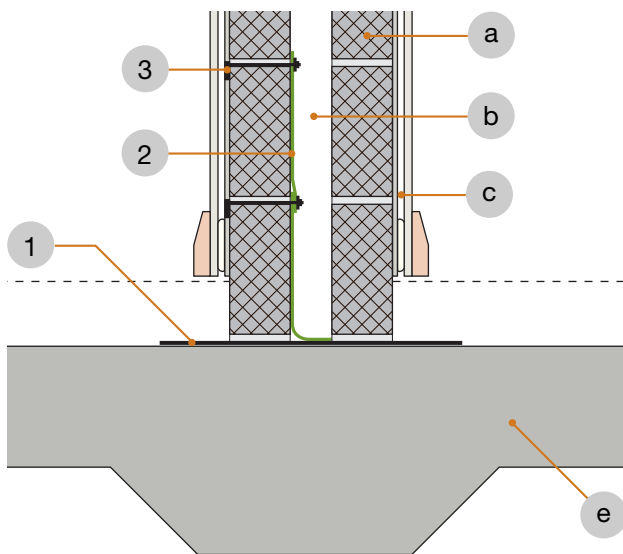

4. Stepped foundation

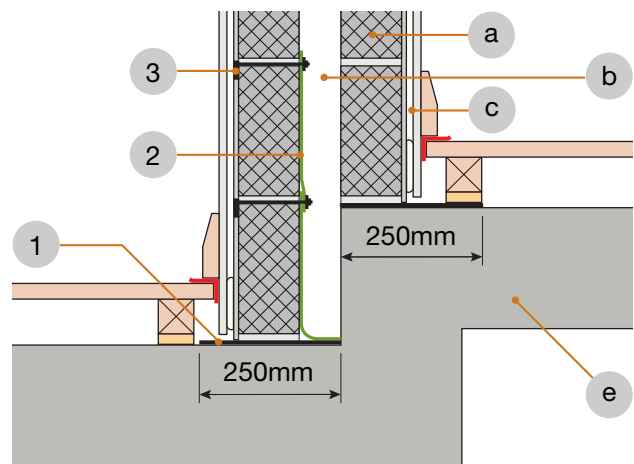

Key

- 1 500mm wide (or 250mm where shown) MONARFLOOR® BRIDGESTOP® 3mm HP Acoustic Membrane laid under the party wall over the dpm. This is an integral part of the system.
- 2 MONARFLOOR® BRIDGESTOP® Quilt in two lifts to prevent mortar droppings touching both masonry leaves.
- 3 MONARFLOOR® BRIDGESTOP® Tie to penetrate at max 450mm centres. Ties are reversible. May also be used as render depth marker.
- 4 MONARFLOOR® 6mm Acoustic Angled Flanking Strip to isolate screed/insulation from party wall and to isolate skirting board from screed.
- 5 Continuous dpm over the raft where ground gasses are an issue. Contact Icopal for specification.

- a Min 100mm block (with appropriate Type A wall ties) dependent on Robust Detail being used. Refer to Table 6a in the Introduction.
- b Min 75mm or 100mm cavity width dependent on Robust Detail being used.
- c Wall finish dependent on Robust Detail used.
- d Floating screed on insulation; or timber floating floor types FFT2 resilient cradle and batten, FFT3 resilient batten, or FFT4 deep platform system.
- e 150mm (min) thick insitu concrete 365kg/m² (min) mass per unit area or Insulslab SFRC.

Contact details for Icopal-MONARFLOOR®:

Telephone: 0161 866 6540

Fax: 0161 865 8433

E-mail: acoustics.uk@icopal.com

Appendix A2 – Proprietary Flanking Conditions

Smartroof complete interlocking “room-in-roof” panel system using **robustdetails®** timber or masonry cavity walls. Refer to Table 6 in Introduction.

1. Gable flanking junction – masonry

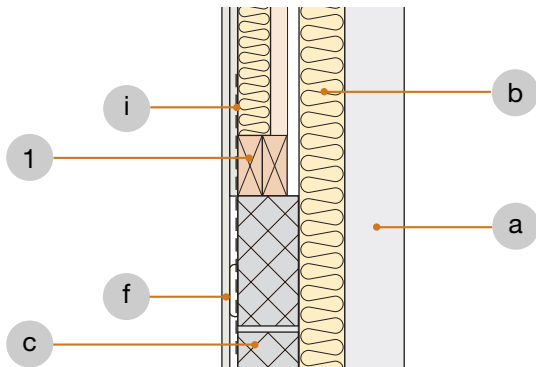

2. Room-in-roof junction with masonry cavity walls

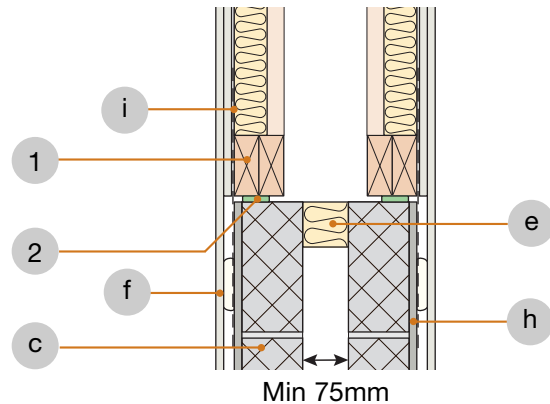

3. Gable flanking junction – timber frame

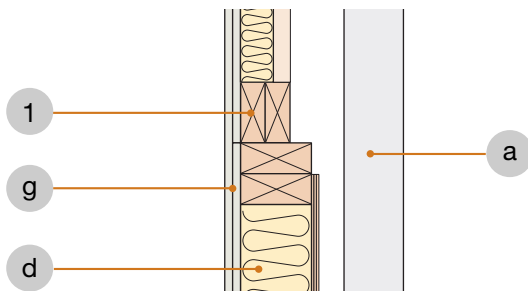

4. Room-in-roof junction with timber frame cavity walls

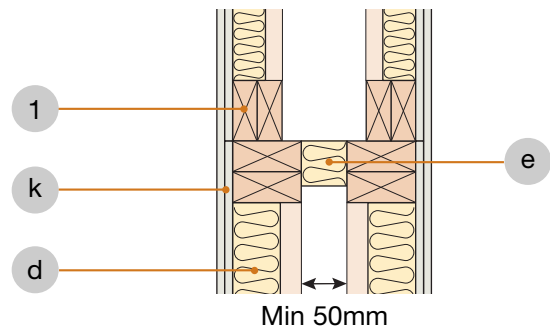

5. Separating wall – roof junction

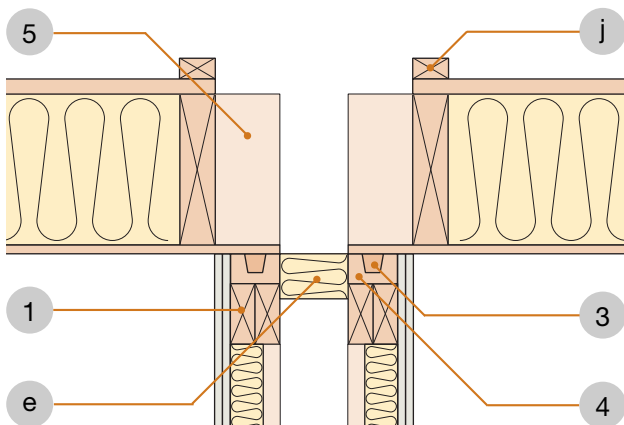

Key

- 1 Smartroof panel.
- 2 Smartroof thin-joint compressed foam to take up unevenness in blockwork.
- 3 Smarttongue 35 x 72mm.
- 4 Smartchannel.
- 5 Smartroof roof panel.

- a Outer leaf of external wall.
- b Continue cavity batts up to gable end if required.
- c Minimum 100mm blockwork.
- d Timber frame inner leaf.
- e Cavity closer.
- f Gypsum-based board dependent on Robust Detail being used.
- g Gypsum-based board nominal 8 kg/m². 2 layers required where separating floors are used (refer to **robustdetails®** separating floor).
- h Nominal 8mm render coat (refer to relevant **robustdetails®** separating wall).
- i Vertical metal straps at 1200mm centres if required.
- j 35 x 50mm counterbatten.
- k 2 layers gypsum-based board total nominal 22 kg/m².

Contact details for smartroof Limited:

Telephone: 01675 44 23 45
Fax: 01675 44 30 95
E-mail: info@smartroof.co.uk
Web: www.smartroof.co.uk

Appendix A2 – Proprietary Flanking Conditions

Kingspan TEK inner leaf flanking condition for **robustdetails**[®] timber separating walls. Refer to Table 6 in Introduction. *Currently when used with separating floors in apartments, separating floors will require pre-completion testing.*

1. External (flanking) wall junction

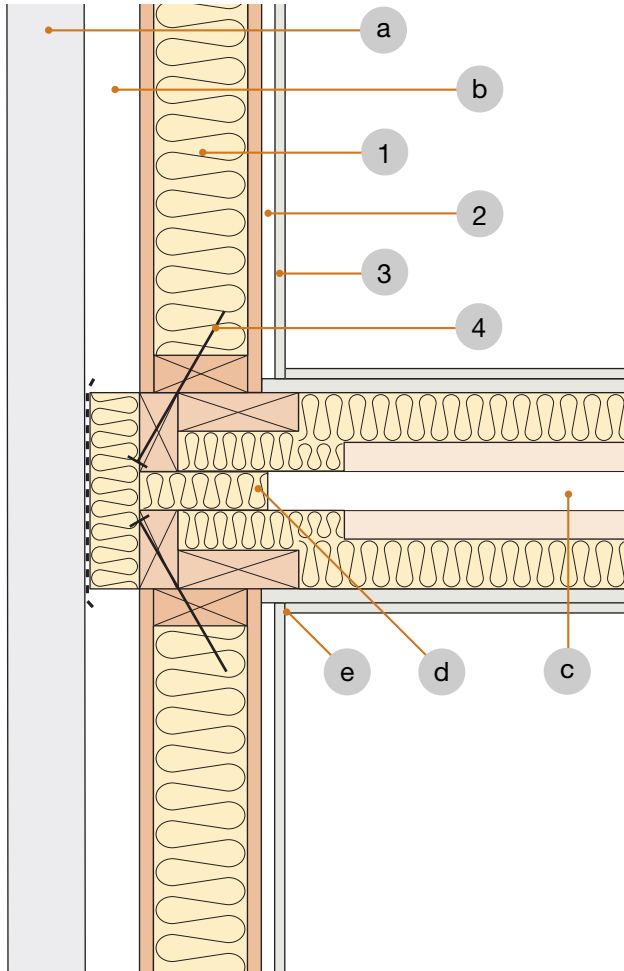

2. Staggered external (flanking) wall junction

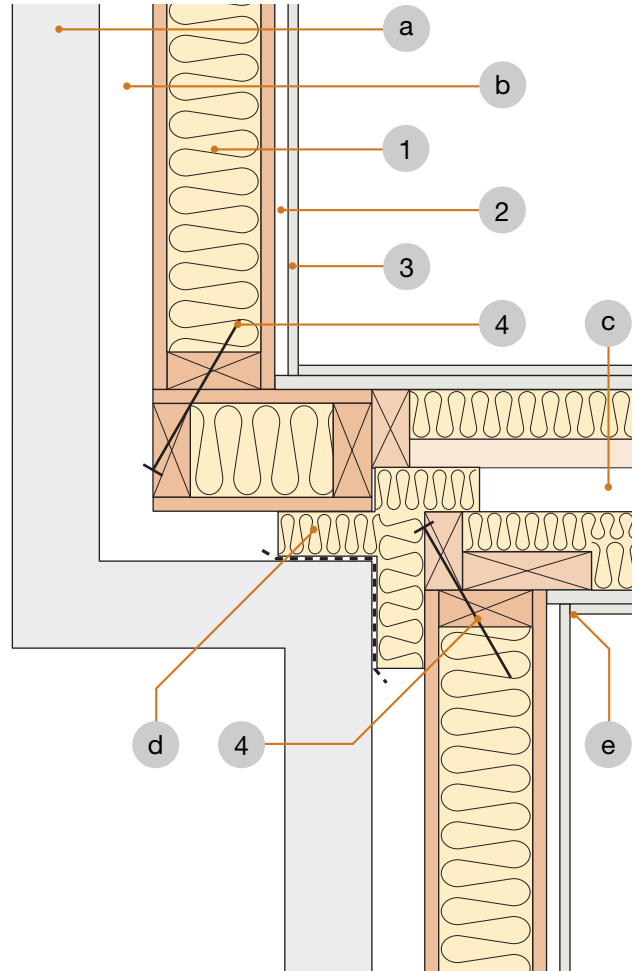

Key

- 1 Kingspan TEK – 142 Panel.
- 2 Service void (if required).
- 3 One layer of gypsum-based board nominal 8 kg/m² on inner leaf where there is no separating floor, e.g. for houses.
Two layers of gypsum-based board nominal 8 kg/m² each on inner leaf where there is a separating floor (non-**robustdetails**[®] floor), e.g. for flats and apartments.
- 4 Approved fixings to TEK BBA Cert No. 02/S029.

- a Masonry outer leaf (min 100mm thick).
- b External wall cavity (min 50mm).
- c **robustdetails**[®] timber frame separating wall. (Refer to Table 6 in Introduction and relevant timber frame Robust Details in Handbook).
- d Close cavity with flexible cavity stop (see Appendix A).
- e Seal all joints with tape or caulk with sealant.

Contact details for Kingspan TEK,
Kingspan Insulation Limited:

Telephone: 01544 387382

Fax: 01544 387482

E-mail: technical.uk@tek.kingspan.com

Web: www.tek.kingspan.com

Appendix A2 – Proprietary Flanking Conditions

Prestoplan PresPeak 60 interlocking single spandrel panel system for use on **robustdetails®** timber separating walls in non room-in-roof situations. Refer to Table 6 in Introduction.

1. Spandrel panel located parallel to trussed rafters

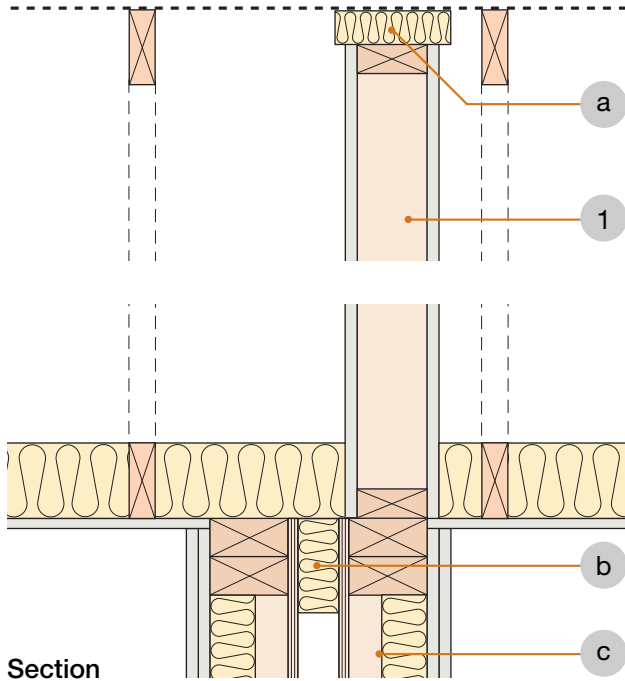

2. Spandrel panel located across trussed rafters

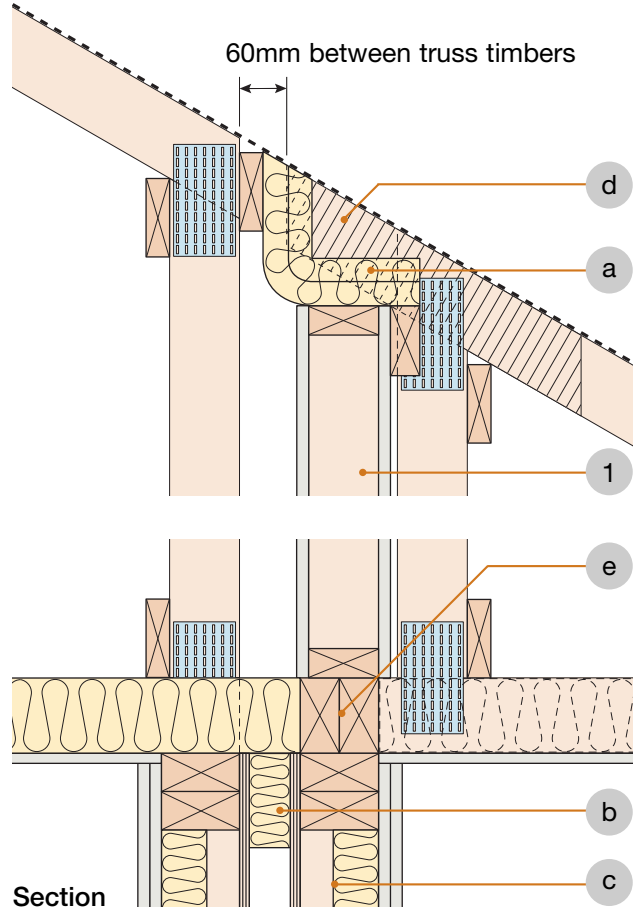

3. Spandrel panel joint detail

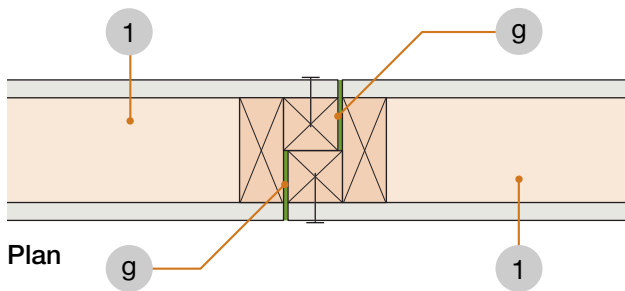

Key

- 1 PresPeak 60 spandrel panels.
- a Firestop wired mineral wool closer.
- b Flexible cavity stop.
- c Timber frame separating wall.
- d Site-fixed rafter extension.
- e Continuous blocking between bottom chords of trusses.
- f Bottom chord extended for support.
- g Intumescent tape.

Top chord detail

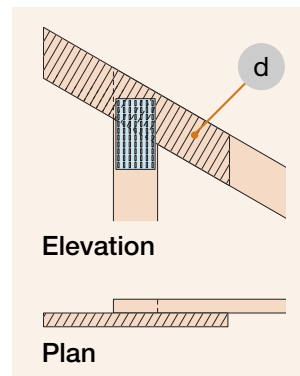

Bottom chord detail

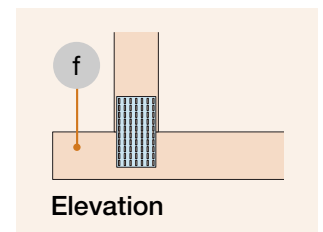

Refer also to manufacturer's guidance

Contact details for Prestoplan Limited:

Telephone: 01772 627373
Fax: 01772 627575
Web: www.prestoplan.co.uk

Appendix A2 – Proprietary Flanking Conditions

Icopal-MONARFLOOR® Wall Cap RDA2 System for **robustdetails®** separating floors in conjunction with cavity walls. Refer to Table 6 in Introduction.

1. External (flanking) wall junction

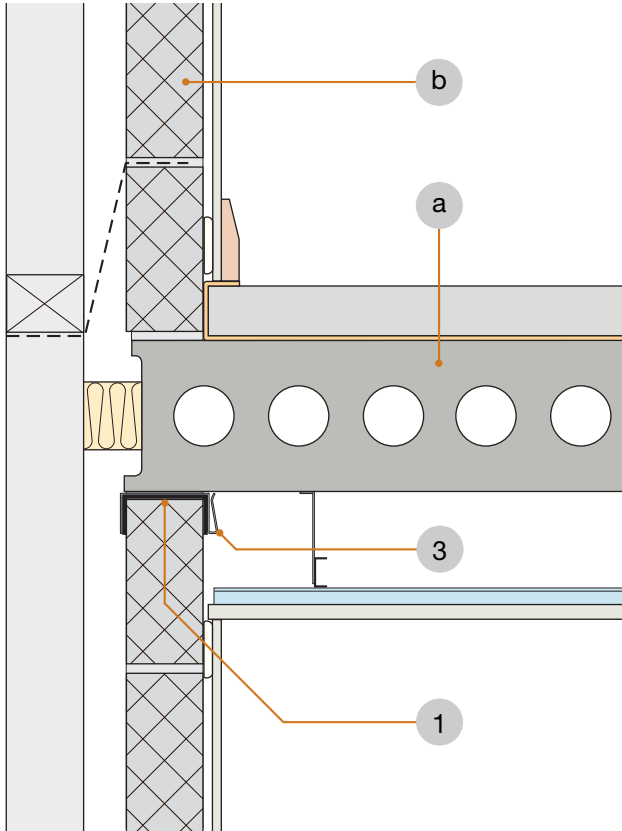

2. Separating wall junction

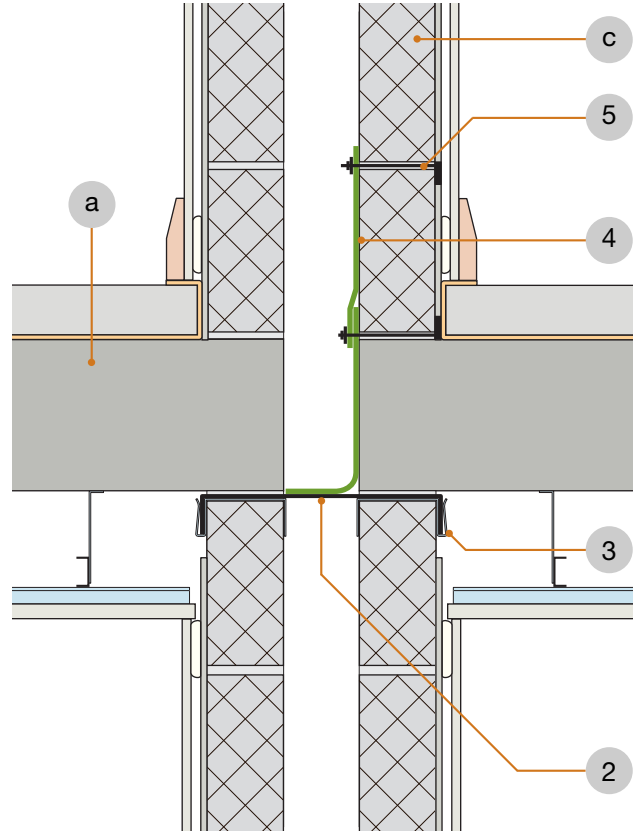

Wall Cap 200
and Wall Cap Clip

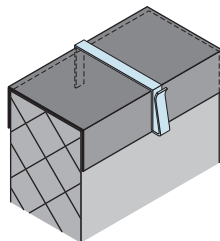

Wall Cap RDA2 Membrane
and Wall Cap RDA2 Clips

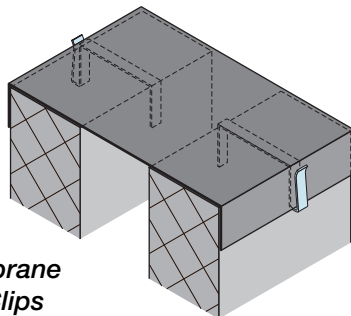

Key

- 1 3.5mm MONARFLOOR® Wall Cap 200 laid as continuous layer on external (flanking) wall.
 - 2 3.5mm MONARFLOOR® Wall Cap RDA2 Membrane laid as continuous layer on separating wall.
 - 3 Wall Cap RDA2 Clips.
 - 4 MONARFLOOR® RDA2 Quilt in two lifts to prevent mortar droppings touching both masonry leaves.
 - 5 MONARFLOOR® RDA2 Tie to penetrate at max 450mm centres. Ties are reversible and may also be used as render depth gauges.
- a **robustdetails®** separating floor. Refer to Table 6 in Introduction.
- b External (flanking) wall. Refer to floor Robust Detail for specification.
- c Separating wall. If using **robustdetails®** separating wall refer to Table 3a in Introduction.

When applying this system to forms of construction other than masonry, please refer to manufacturer's installation guides. Note: In these cases, not all components shown above may be required.

Contact details for Icopal-MONARFLOOR®:

Telephone: 0161 866 6540
Fax: 0161 865 8433
E-mail: acoustics.uk@icopal.com

The trade marks MONARFLOOR and Wall Cap are the subject of UK trade mark registrations owned by Icopal Limited

Appendix A2 – Proprietary Flanking Conditions

RoofSpace I-Roof™ “room-in-roof” panel system using **robustdetails**® timber or masonry cavity walls. Refer to Table 6 in Introduction.

1. Room-in-roof junction with timber frame cavity walls

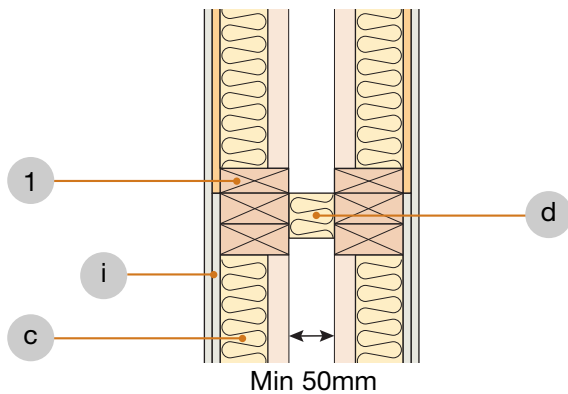

2. Room-in-roof junction with masonry cavity walls

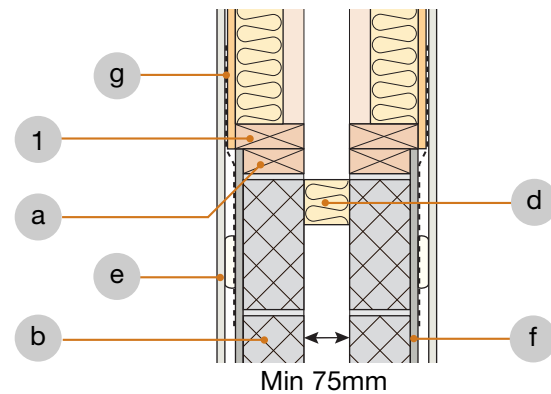

3. Separating wall – roof junction

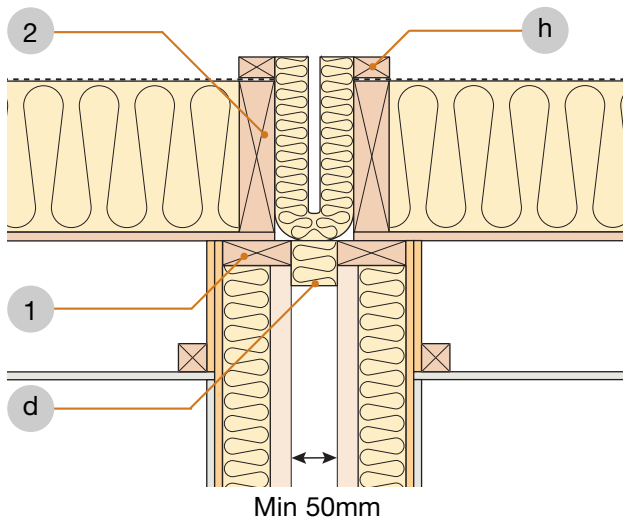

4. Internal floor cassette junction option

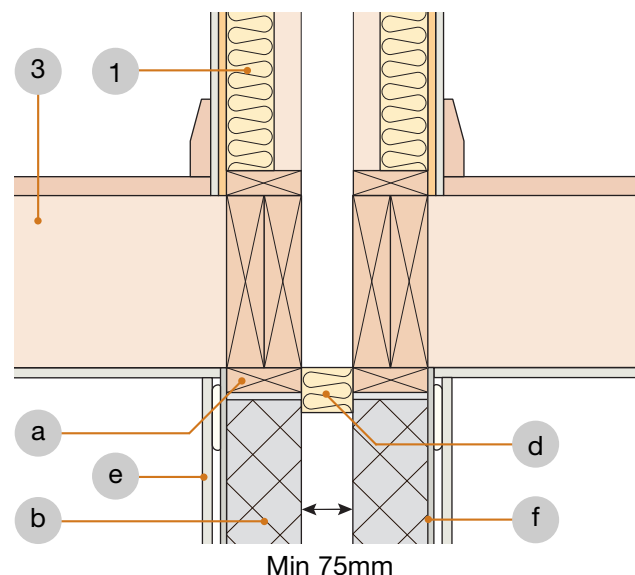

Key

- 1 RoofSpace I-Roof™ spandrel panel.
- 2 RoofSpace I-Roof™ roof panel.
- 3 RoofSpace internal floor cassette.
- a Timber wall plate bedded on 10mm mortar bed to take out unevenness in blockwork.
- b Minimum 100mm blockwork.
- c Timber frame separating wall leaf.
- d Cavity closer.
- e Gypsum-based board dependent on Robust Detail being used.
- f Nominal 8mm render coat (refer to relevant **robustdetails**® separating wall).
- g Vertical metal straps at 1200mm centres if required.
- h 25 x 38mm counterbatten.
- i 2 layers gypsum-based board total nominal 22 kg/m².

Spandrel panel cavity insulation (optional)

The cavity between the spandrel panels may be insulated with mineral wool rolls or batts with a density of 18–40 kg/m³. Ensure insulation thickness is no greater than 10mm wider than cavity width to avoid excessive compression of the insulation.

Contact details for SIG RoofSpace:

Telephone: 01789 209 006
Fax: 01789 292 858
E-mail: technical@sigroofspace.co.uk
Web: www.sigroofspace.co.uk

Appendix A2 – Proprietary Flanking Conditions

Space4 “room-in-roof” panel system using **robustdetails**[®] timber or masonry cavity walls. Refer to Table 6 in Introduction.

1. Non room-in-roof spandrel panel to timber separating wall junction

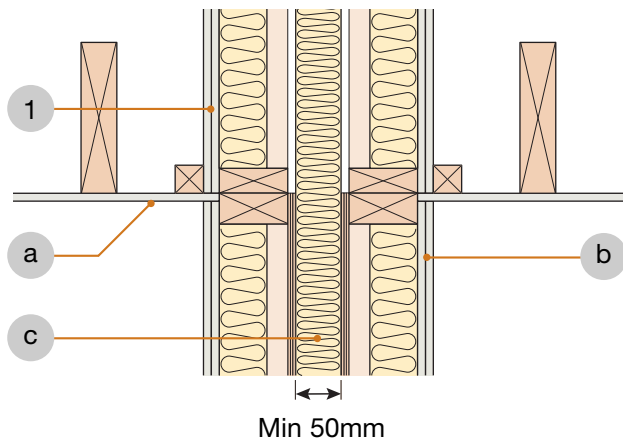

2. Spandrel panel to masonry separating wall junction

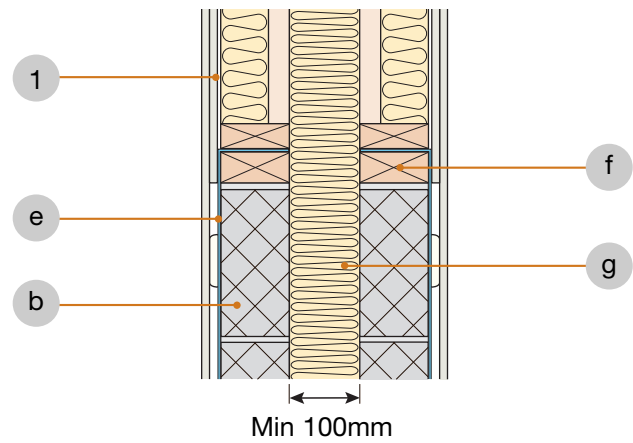

3. Roof cassette to timber separating wall junction for room-in-roof

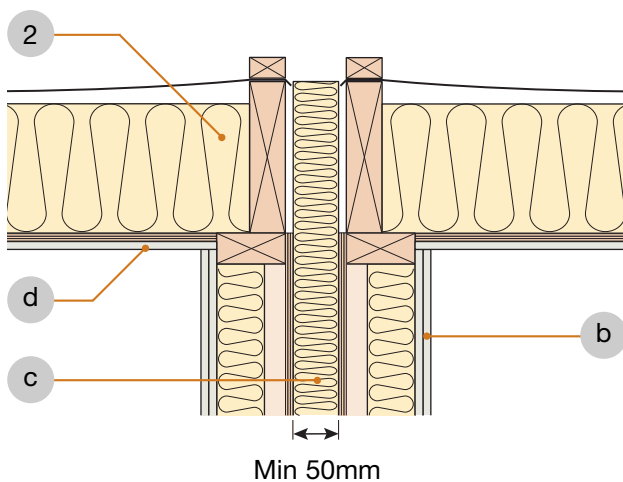

4. Internal floor junction for room-in-roof

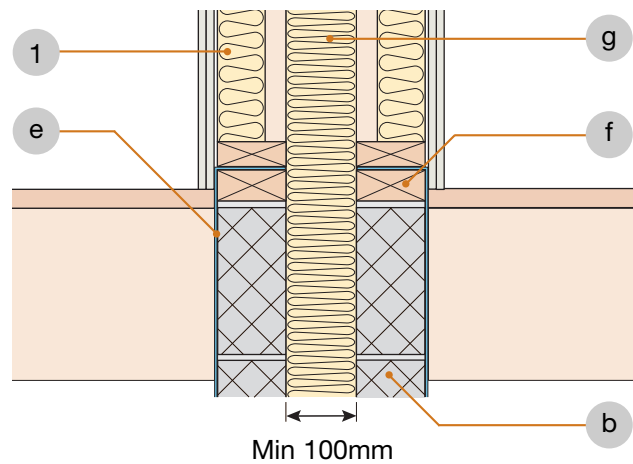

Key

1 Space4 spandrel panel.

2 Space4 roof cassette.

a Minimum 1 layer nominal 8 kg/m² gypsum-based board to ceiling.

b **robustdetails**[®] separating wall.

c Mineral wool 18-40 kg/m³.

d OSB underdraw overlaid with minimum 1 layer gypsum-based board nominal 16 kg/m² total.

e Vertical metal straps at 1200mm centres if required.

f Wall plate fully bedded on mortar with no gaps.

g Mineral wool 12-25 kg/m³.

Contact details for Space4:

Telephone: 0121 748 8383

Fax: 0121 776 7369

E-mail: technical@space4.co.uk

Web: www.space4.co.uk

Appendix A2 – Proprietary Flanking Conditions

Stewart Milne Timber Systems Sigma® Roof Spandrel Panel System for use on **robustdetails®** timber separating walls in non room-in-roof situations.
Refer to Table 6 in Introduction.

1. Spandrel panel located parallel to trussed rafters

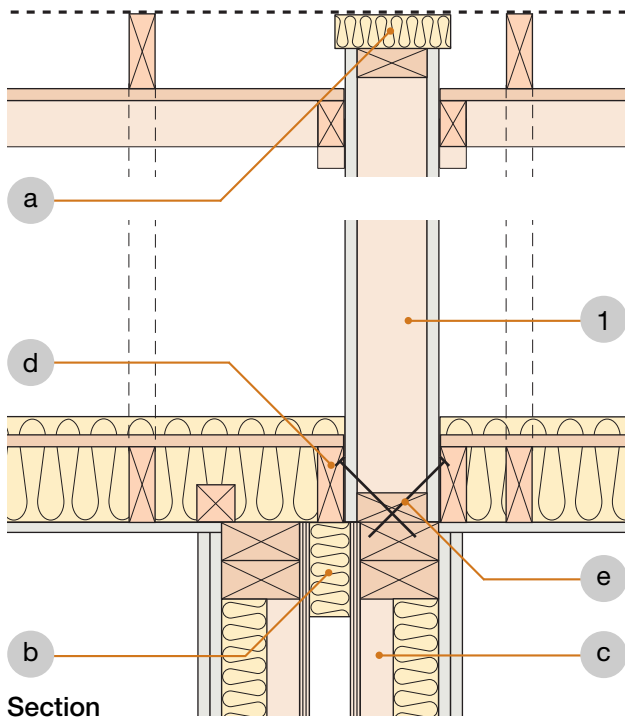

2. Spandrel panel located across trussed rafters

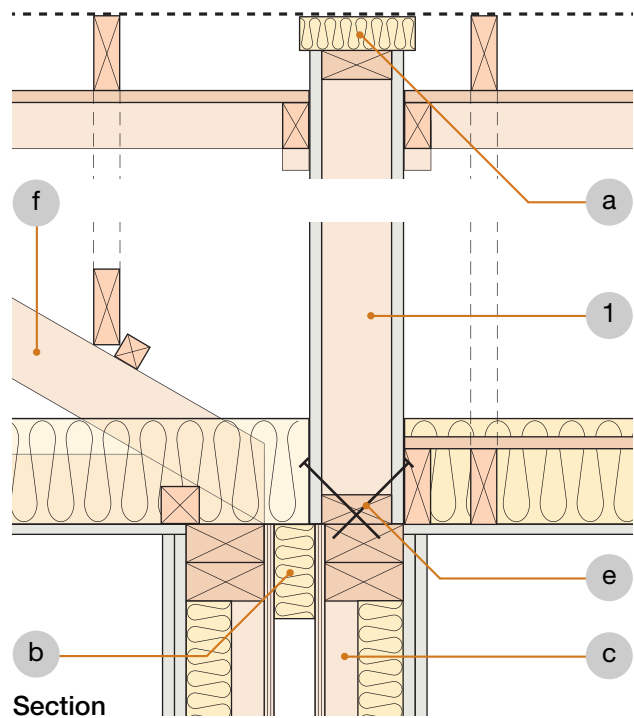

3. Spandrel panel joint detail

Panels secured together using angled screw fixings

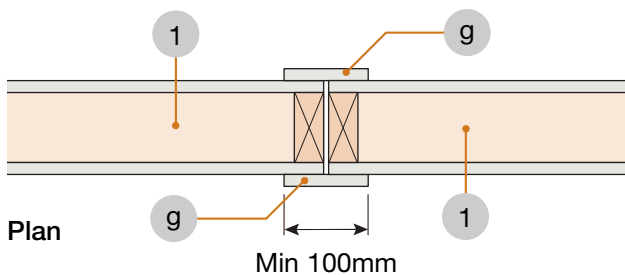

Key

- 1 Stewart Milne Timber Systems Sigma® Roof Spandrel Panel System.
- a Mineral wool closer.
- b Flexible cavity stop.
- c Timber frame separating wall.
- d Site-fixed runners must not contact both wall leaves.
- e Angled screw fixings to secure spandrel to wall head.
- f Trusses and rafters must not contact both wall leaves.
- g Gypsum board cover strip.

Refer also to manufacturer's guidance

Contact details for
Stewart Milne Timber Systems Limited:

Telephone: 01865 303900
Fax: 01865 303999
Email: smts@stewartmilne.com
Web: www.stewartmilne.com

Appendix A2 – Proprietary Flanking Conditions

NYTROOF RAPID FIT SYSTEM for **robustdetails®** masonry cavity walls for “room-in-roof” situations. Refer to Table 6 in Introduction.

1. Gable flanking junction – masonry

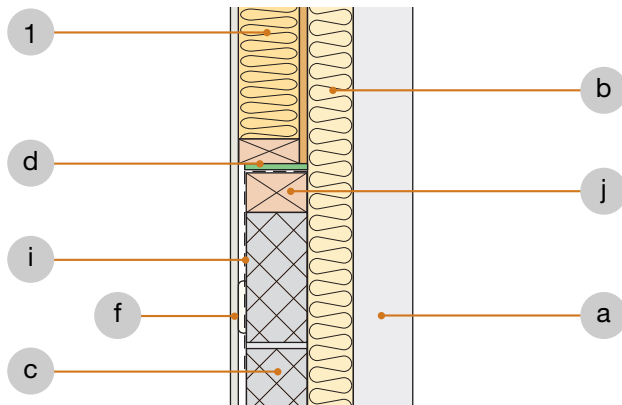

2. Room-in-roof junction with masonry cavity walls

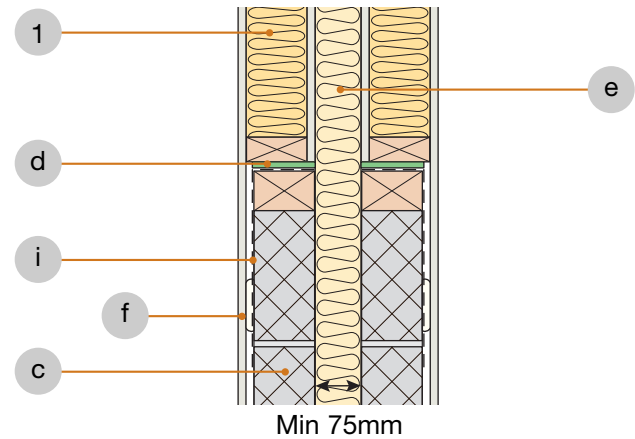

3. Separating wall – roof junction

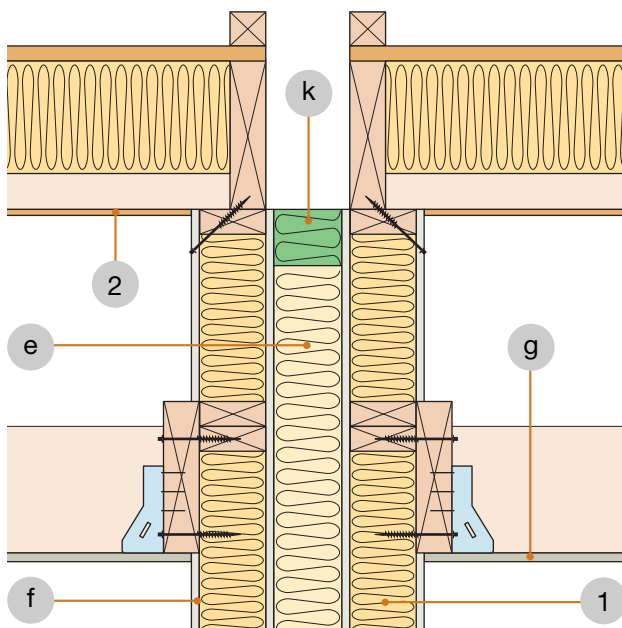

2. Room-in-roof lining requirements

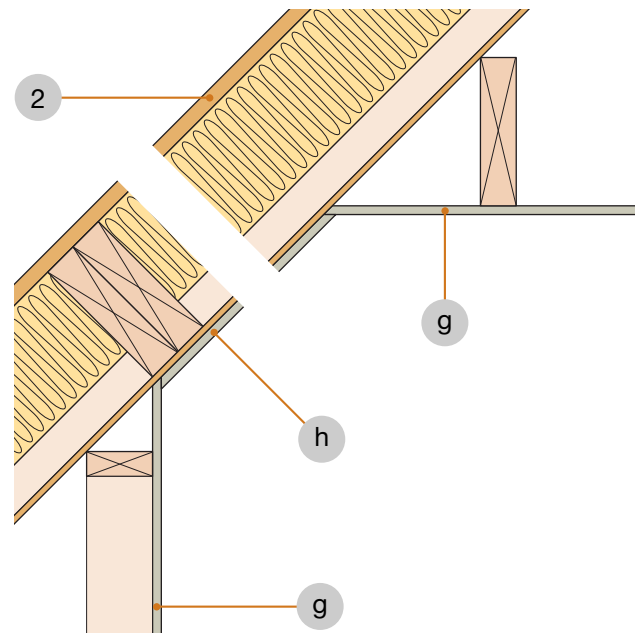

Key

- a Outer leaf of external wall.
- b Continue cavity batts up to gable end if required.
- c Blockwork dependent on Robust Detail used.
- d Intumescent sealant.
- e Cavity insulation dependent on Robust Detail used.
- f Gypsum-based board (nominal 10 kg/m²).
- g Gypsum-based board (nominal 8 kg/m²)
- h Min. 1 layer gypsum-based board (nominal 10 kg/m²).
- i Vertical metal straps if required. Straps must not extend into the cavity.
- j Wall plate bedded on mortar, notched to take straps.
- k Cavity closer.

- 1 NYTROOF spandrel panel.
- 2 NYTROOF roof cassette.

Contact details for NYTimber:

Telephone: 01609 751111
Fax: 01609 788388
E-mail: grayden@nytimber.co.uk
Web: www.nytimber.co.uk/

Appendix A2 – Proprietary Flanking Conditions

Lightweight external cladding treatments for robustdetails® timber separating walls. Refer to Table 6 in Introduction. *Currently when used with separating floors in apartments, separating floors will require pre-completion testing.*

External (flanking) wall junction

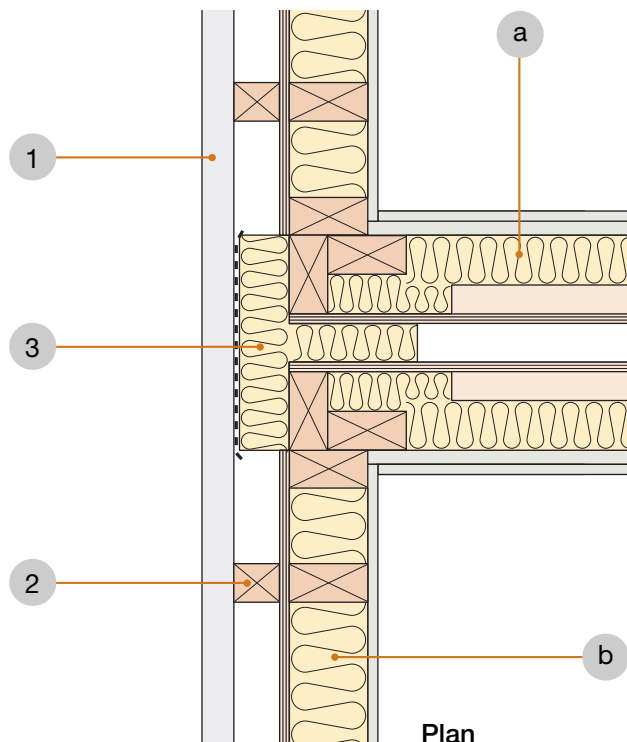

Key

- 1 Cladding system (see Table below).
- 2 Cladding support rails (timber or metal).
Horizontal rails fixed directly to the wall structure must not be continuous across the separating wall.
- 3 Flexible cavity closer to fully close the cavity behind the cladding.
- a Separating wall. See chosen Robust Detail for specification.
- b Inner leaf of external wall. See chosen Robust Detail for specification.

Acceptable cladding types

Render board	Systems having minimum 9mm rigid render board with minimum mass per unit area of 12.4 kg/m ² . It is acceptable to have multiple board layers.
--------------	---