

Solid dense aggregate block separating wall taken from raft foundations for use in houses

E-WM-9

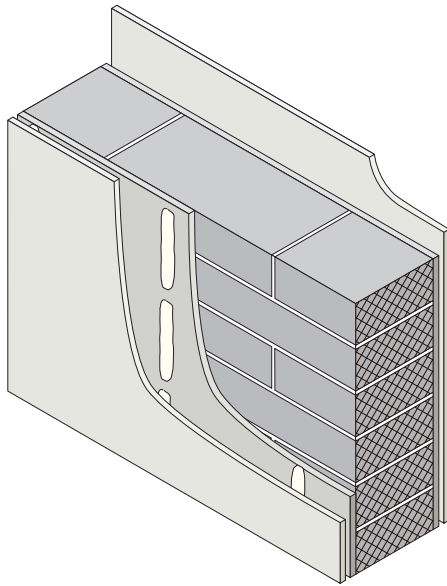

E-WM-9 requires the separating wall to be formed from 440 x 100 x 215mm dense aggregate blocks, within the range 1850-2300 kg/m³. It must be possible to identify through manufactured mark or feature that the constructed wall has used the correct block type.

Blocks that Robust Details Limited have currently acknowledged as carrying such identification features will appear on this list, the current version of which is available on our website www.robustdetails.com.

Full details of E-WM-9 are shown in the Robust Details Part E Handbook.

IMPORTANT - It is not acceptable to use blocks that do not appear on the current list

List of blocks accepted by Robust Details Limited for use in E-WM-9

Manufacturer	Name of Block	Identification feature	Website	View
Masterblock	Masterdenz RD	Two, 10-12mm diameter grooves on one end of the block	www.masterblock.co.uk	Page 2
Tarmac	Topcrete RD	Single 10mm diameter groove on each end of the block	www.tarmac.co.uk	Page 3
Stowell Concrete Ltd	Stowell RD	Single 12mm diameter groove on one end of the block	www.stowellconcrete.co.uk	Page 4
Lignacite Ltd	Lignacrete WM9	Blocks factory pigmented red	www.lignacite.co.uk	Page 5
Besblock	Besblock dB Performer	Two, 10-12mm diameter grooves on one end of the block	www.besblock.co.uk	Page 6
Interfuse Ltd	Intercrete RD	Single 20mm diameter groove on each end of the block	www.interfuseblocks.com	Page 7
Forticrete	Newcon RD	Single 20mm wide, 10mm deep groove on one end of the block	www.forticrete.co.uk	Page 8
Gryphonn Concrete Products Ltd	Dense Concrete RD	Blocks factory pigmented red	www.gryphonn.co.uk	Page 9
Plasmor Concrete Products Ltd	PLASCON	Single 15mm diameter groove	www.plasmor.co.uk	Page 10
Mona Precast (Anglesey) Ltd	Monacrete RD	Blocks factory pigmented red	www.monaprecast.co.uk	Page 11

If you are a block manufacturer and have a dense aggregate block that you believe meets Robust Details Limited's identification criteria and you wish to be considered for inclusion on the list above please e-mail technical@robustdetails.com or write to:

Robust Details Limited, Unit 14, Shenley Pavilions, Chalkdell Drive, Shenley Wood, Milton Keynes, MK5 6LB

Solid dense aggregate block separating wall taken from raft foundations for use in houses

E-WM-9

Masterblock: Masterdenz RD

Identified by: Two, 10-12mm diameter grooves on one end of the block

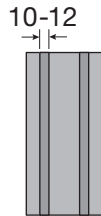

End elevation

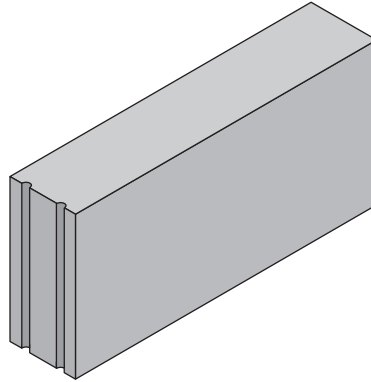

Isometric view



Appearance of Masterdenz RD separating wall as built

Solid dense aggregate block separating wall taken from raft foundations for use in houses

E-WM-9

Tarmac: Topcrete RD

Identified by: Single 10mm diameter groove on each end of the block

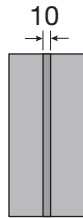

End elevation

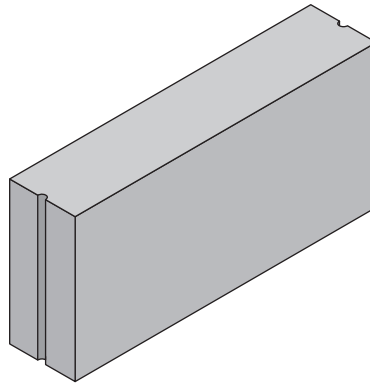

Isometric view



Appearance of Topcrete RD separating wall as built

Solid dense aggregate block separating wall taken from raft foundations for use in houses

E-WM-9

Stowells Concrete Ltd: Stowells RD

Identified by: Single 12mm diameter groove on one end of the block



End elevation

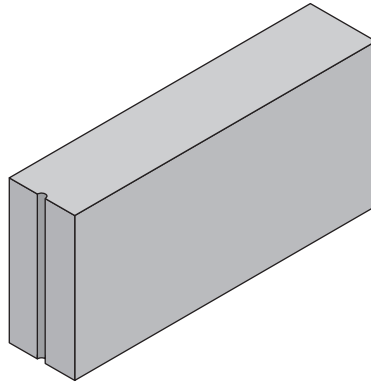

Isometric view



Appearance of Stowells RD separating wall as built

Solid dense aggregate block separating wall taken from raft foundations for use in houses

E-WM-9

Lignacite Ltd: Lignacrete WM9

Identified by: Blocks factory pigmented red

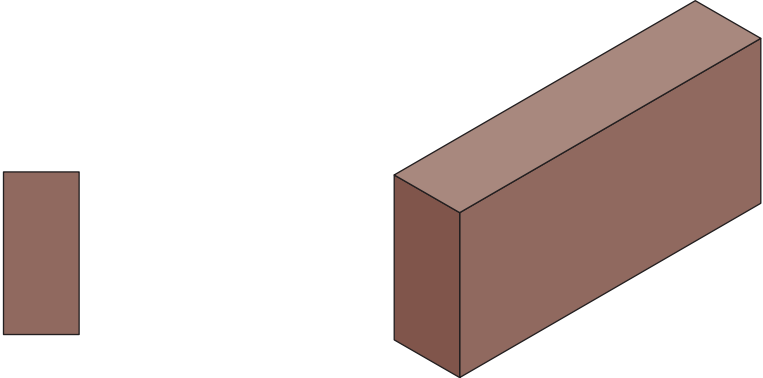

End elevation

Isometric view



Appearance of Lignacite WM9 separating wall as built

Solid dense aggregate block separating wall taken from raft foundations for use in houses

E-WM-9

Besblock: Besblock dB Performer

Identified by: Two, 10-12mm diameter grooves on one end of the block

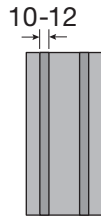

End elevation

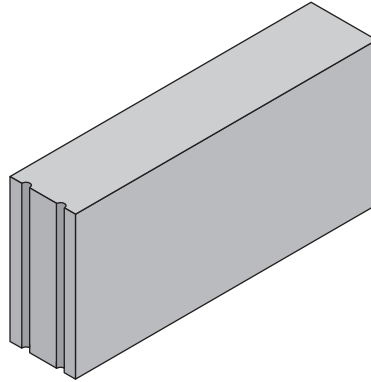

Isometric view



Appearance of Besblock dB Performer separating wall as built

Solid dense aggregate block separating wall taken from raft foundations for use in houses

E-WM-9

Interfuse Ltd: Intercrete RD

Identified by: Single 20mm diameter groove on each end of the block

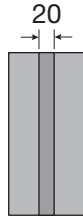

End elevation

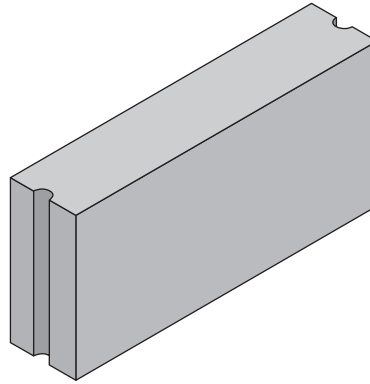

Isometric view



Appearance of Intercrete RD separating wall as built

Solid dense aggregate block separating wall taken from raft foundations for use in houses

E-WM-9

Forticrete: Newcon RD

Identified by: Single 20mm wide, 10mm deep groove on one end of the block

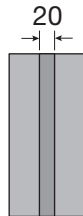

End elevation

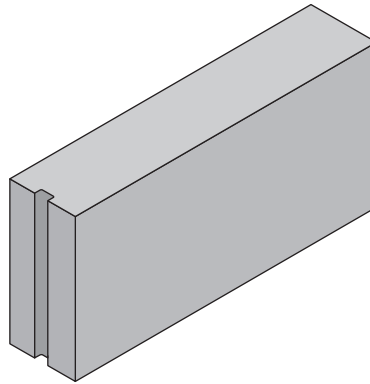

Isometric view

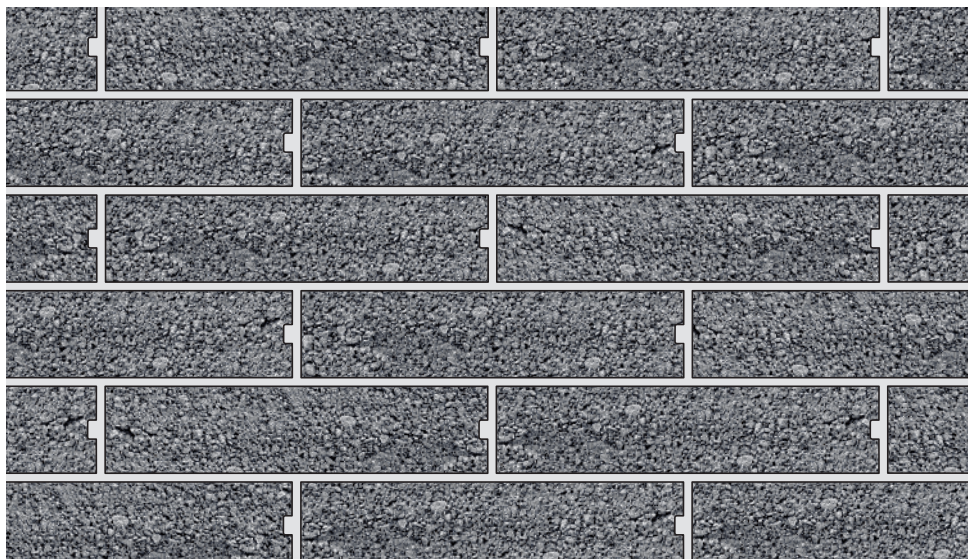

Appearance of Newcon RD separating wall as built

Solid dense aggregate block separating wall taken from raft foundations for use in houses

E-WM-9

Gryphonn Concrete Products Ltd: Dense Concrete RD

Identified by: Blocks factory pigmented red



End elevation

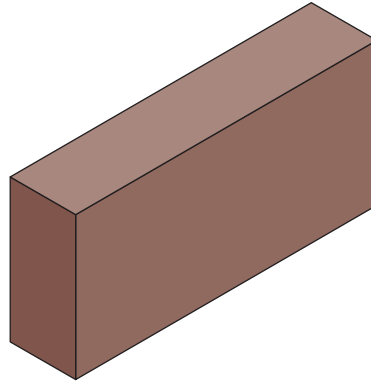

Isometric view



Appearance of Gryphonn Dense Concrete RD separating wall as built

Solid dense aggregate block separating wall taken from raft foundations for use in houses

E-WM-9

Plasmor Concrete Products Ltd: PLASCON

Identified by: Single 15mm diameter groove on one end of the block

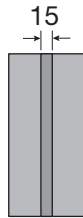

End elevation

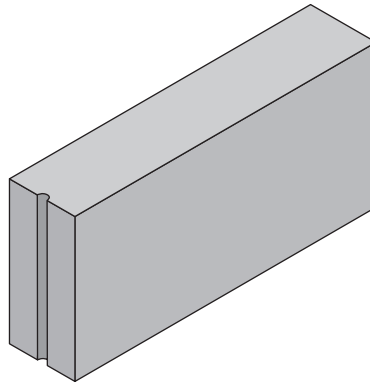

Isometric view



Appearance of PLASCON separating wall as built

Solid dense aggregate block separating wall taken from raft foundations for use in houses

E-WM-9

Mona Precast (Anglesey) Ltd: Monacrete RD

Identified by: Blocks factory pigmented red

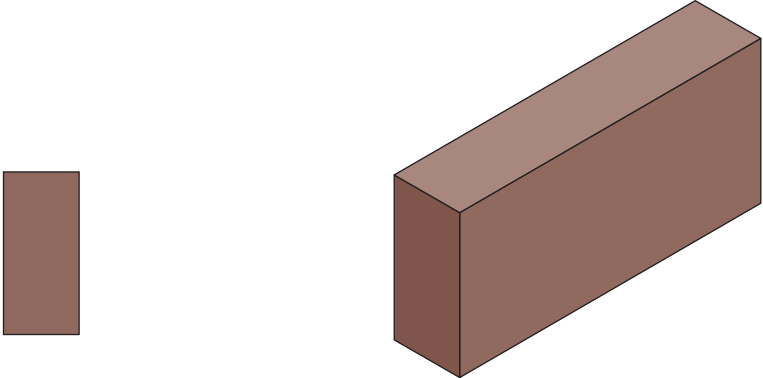

End elevation

Isometric view



Appearance of Monacrete RD separating wall as built